



**EQUESTRIAN
CANADA
ÉQUESTRE**

**SECTION F
GENERAL PERFORMANCE, WESTERN, EQUITATION**

Rules of Equestrian Canada
2026

CLEAN COPY EDITION

This document contains the final text effective January 1, 2026.

EQUESTRIAN CANADA RULEBOOK

The rules published herein are effective on January 1, 2026, and remain in effect for one year except as superseded by rule changes or clarifications published in subsequent editions of this section. Section F as printed herein is the official version of *General Performance, Western, Equitation* for 2026.

The Rule Book comprises the following sections:

- A General Regulations
- B Breeds
- C Driving and Para-Driving
- D Eventing
- E Dressage and Para Dressage
- F General Performance, Western, Equitation
- G Hunter, Jumper, Equitation and Hack
- J Endurance
- K Reining and Para-Reining
- L Vaulting

Section F: GENERAL PERFORMANCE, WESTERN, EQUITATION

is part of the Rulebook of Equestrian Canada
and is published by:

EQUESTRIAN CANADA

c/o House of Sport
2451 Riverside Drive
Ottawa, Ontario K1H 7X7
Tel: (613) 287-1515; Fax: (613) 248-3484
1-866-282-8395
Email: rules@equestrian.ca
Web site: www.equestrian.ca

A General Performance competition may be conducted as an EC sanctioned Bronze or Silver competition. A General Performance competition will consist of a minimum, mandatory 40% Western classes taken from Western Performance, Western Equitation and Western Timed Event sections. Additional classes may be selected from the other sections of General Performance, but must not exceed 60% of the total classes offered in the competition.

EQUESTRIAN CANADA GENERAL PERFORMANCE COMPETITION CHART		
GENERAL PERFORMANCE	BRONZE	SILVER
	Sport Licence *	Sport Licence *
	Upgrade fee * to Silver- purchase from Event	Upgrade fee * to Gold - purchase from Event
Membership	Yes	Yes
Sport Licence	Yes	Yes
Horse Recording	No	When available
Insurance Required	Yes	Yes
Prize Money allowed	\$5,000	\$10,000 to \$15,000 for championships
Days of operation	5	5
Show licence fee	EC Show Fees	EC Show Fees
Show Approval	PPTSO	PPTSO
Prize List Approval	PPSO / delegate	PPSO / delegate
EC Rules	GP Mandatory	GP Mandatory
Liability Insurance	Mandatory	Mandatory
On Site Medical/Safety Plan	Mandatory	Mandatory
Veterinarian	On call	On call
Drug Fees collected	Yes	Yes
Equine Medication Control	Random	Random
Mandatory Sections - core classes in each	Western Performance & Equitation	Western Performance & Equitation
Optional Sections: Note: Western Performance, Western Speed, Western Equitation and Halter Classes must comprise at least 40% of the classes offered at a General Performance Competition	Western Speed; English Performance (Fences); English Flat; Halter	Western Speed; English Performance (Fences); English Flat; Halter
Permitted classes		
Hunter	2'3"; 2'6"; 2'9"; 3'0"	2'3"; 2'6"; 2'9"; 3'0"; 3'3"
Jumper – must use a Course Designer	2'3"; 2'6"; 2'9"; 3'0" [0.7m; 0.75m; 0.85m; 0.90m]	2'3"; 2'6"; 2'9"; 3'0"; 3'3" [0.7m up to 1.0m]
Championships	PTSO: Championship for each class in Sections and by Section	
Points awarded	PTSO: Accumulated: 1 st -6 pts. to 6 th – 1 pt.	
Officials		
Judges	Provincial/GP r/Breed R	GP Sr.
Stewards	Yes	Yes
Games Goal	Regional/Zone	Provincial

Metric conversions: 2'3"=0.70m; 2'6"=0.85m; 3'0"=0.90m; 3'3"=1m; 3'6"=1.10m

* EC Schedule of Fees – www.equestrian.ca

EQUESTRIAN CANADA RULE BOOK

SECTION F GENERAL PERFORMANCE, WESTERN, EQUITATION

These Rules are to be used in conjunction with the General Regulations of Equestrian Canada.

TABLE OF CONTENTS

THE EQUESTRIAN CANADA RULEBOOK	v
PART ONE GENERAL PERFORMANCE AND WESTERN JUDGES.....	1
Chapter 1 General Performance Judges	1
Chapter 2 Western Judges	2
PART TWO GENERAL PERFORMANCE AND WESTERN COMPETITIONS.....	3
Chapter 3 General Rules for General Performance Competitions	3
Chapter 4 General Rules for Western Competitions.....	4
Chapter 5 General Tack and Equipment Rules for General Performance & Western Competitions	5
PART THREE WESTERN PERFORMANCE CLASSES.....	6
Chapter 6 Western Performance Classes	6
Chapter 7 Western Equipment and Attire.....	10
Chapter 8 Western Pleasure.....	14
Chapter 9 Trail Horse	16
CHAPTER 10 WESTERN RIDING	27
Chapter 11 Command Class	33
Chapter 12 General Performance Reining	34
Chapter 13 Ranch Riding.....	38
CHAPTER 14 RANCH TRAIL	44
CHAPTER 15 WORKING WESTERN RAIL.....	48
PART FOUR WESTERN TIMED CLASSES.....	50
Chapter 16 Western Speed Events.....	50
PART FIVE ENGLISH PERFORMANCE CLASSES.....	61
Chapter 17 General Performance Hunter.....	61
Chapter 18 General Performance Hunter Hack	65
Chapter 19 General Performance Jumper	66
PART SIX ENGLISH UNDER SADDLE CLASSES.....	71
Chapter 20 Hunter Under Saddle.....	71
Chapter 21 General Performance Hack Classes.....	72
PART SEVEN GENERAL PERFORMANCE SHOWMANSHIP CLASSES	75

Chapter 22	General PERFORMANCE Showmanship at Halter.....	75
PART EIGHT	GENERAL PERFORMANCE EQUITATION CLASSES ..	78
Chapter 23	General Performance Equitation Rules	78
Chapter 24	General Performance Hunt Seat Equitation.....	79
Chapter 25	Western Horsemanship	83
PART NINE	GENERAL PERFORMANCE HALTER CLASSES	86
Chapter 26	Breeding/Halter Classes	86
Appendix 1	Hunter and Jumper: Diagrams and Charts: Distances.....	88
GLOSSARY	89
METRIC CONVERSION	106
INDEX	107

EQUESTRIAN CANADA

Equestrian Canada is the national governing body for equestrian sport in Canada, with a mandate to represent, promote and advance the sport in Canada, and to represent, promote advocate for and advance all related equine and equestrian interests, including recreation, industry and equine health and welfare.

PATRON

Her Excellency the Right Honourable Mary Jeannie May Simon CC., CMM.,
COM., OQ., CD., FRCGS., Governor General of Canada

THE EQUESTRIAN CANADA RULEBOOK

Knowledge of the rules of any sport is required of each participant, and the exhibitor at an EC-sanctioned competition must accept this responsibility. Both a complete knowledge of and compliance with the rules are essential, and all participants must be fully cognizant of all rules as well as particular class specifications in the discipline/breed sport in which they compete.

It is not possible to provide for every conceivable eventuality in these rules. If there is no rule to deal specifically with a particular circumstance, or if the nearest interpretation of the pertinent rule would result in an obvious injustice, it is the duty of those responsible to make a decision based on common sense and fair play, thus reflecting as closely as possible the intention of the rules and regulations of Equestrian Canada.

Organization of the Rulebook

The EC Rulebook is divided into multiple sections, grouped by disciplines and breed sports. Section A covers general regulations that apply to all EC members, competitors, officials, owners, equines, organizers and persons responsible unless superseded in other sections of the Rulebook.

Evergreen Rules Process

The Equestrian Canada rulebooks are updated annually, effective January 1st. The official rulebook will be as published on the EC website and may be amended as follows.

Amendment of the Rules

It is the right of every Sport Licence holder of Equestrian Canada to propose amendments to the rules, subject to the current policies, procedures and schedules. The deadline for Rule Change Suggestions (RCS) shall be May 31 each year in accordance with the procedures outlined on the EC Rule Change page. Suggestions will be reviewed by the appropriate discipline/breed sport EC committees who will consider all suggestions and put forward those they recommend as Rule Change Proposals (RCPs). RCPs will be posted on the EC website to allow for a 30-day review period. The EC committees will consider all comments and make any necessary revisions. Rule changes will be posted on the EC website in December to be effective January 1 the following year.

The amendment process will be strictly followed. Extraordinary rule amendments will be permitted only for FEI rule changes, safety, monetary, clarification, ethical and equine welfare reasons at the discretion of the National Rules Committee using the following protocol. Extraordinary rule amendments will be effective when published by EC on its official website. FEI Rules, applicable to EC-sanctioned competitions, are effective upon publication by the FEI.

Extraordinary Amendment Process

1. **Proposal** – An Extraordinary Rule Amendment (ERA) is composed by the EC discipline/breed committee, EC staff or National Rules Committee (NRC) with supporting rationale.
2. **Authorization** – The applicable discipline or breed committee must authorize each ERA, note it in their minutes and forward it to the NRC.
3. **Approval** – The NRC is responsible for confirming the ERA criteria (FEI rule change, safety, monetary, clarification, ethical or equine welfare) have been satisfied
4. **Posting** – EC will translate and post the amendment and show changes to both change visible and clean copy online Rulebooks. The amendments display the date of the NRC approval for consistency.
5. **Effective** – An ERA is effective when published on the EC website. The file reference shall retain the original approval date.

Interpretation of the Rules

Please read all cross-references carefully and refer to the EC website for rule changes and/or clarifications. Should the English and French versions differ, the English version shall prevail. In the case of conflict between General Regulations and the regulations of the disciplines/breed sports, the discipline/breed sport rules will prevail.

PART ONE

GENERAL PERFORMANCE AND WESTERN JUDGES

CHAPTER 1

GENERAL PERFORMANCE JUDGES

ARTICLE F101 REQUIRED JUDGES

1. EC-sanctioned Silver General Performance competitions must use Senior General Performance Judges.
2. EC-sanctioned Bronze competition may use either a Recorded or Senior General Performance Judge. Provincial certified judges may be used at Bronze competitions but they must possess a current EC Bronze Sport Licence and should have attended an EC General Performance judging seminar within the past three years.
3. EC Western judges may officiate only at a Western competition and not in other General Performance sections.

ARTICLE F102 GENERAL

1. Recorded General Performance Judges may officiate at Bronze competitions.
2. Senior General Performance Judges may officiate General Performance division classes when offered in EC-sanctioned Bronze and Silver competitions.
3. General Performance judges may officiate at competitions in Canada which are not sanctioned by EC.

ARTICLE F103 CLASSES QUALIFIED TO JUDGE

A General Performance Judge is qualified to judge:

- Western Pleasure
- Trail Horse
- Western Riding
- Command Class
- General Performance Reining
- Western Speed Events
- General Performance Hunter
- General Performance Hunter Hack
- General Performance Jumper
- General Performance Hunter Under Saddle
- General Performance Hack Classes
- General Performance Showmanship
- General Performance Hunt Seat Equitation
- General Performance Western Horsemanship
- Breeding/Halter classes

CHAPTER 2 WESTERN JUDGES

ARTICLE F201 REQUIRED JUDGES

1. EC-sanctioned Silver Western competitions must use a Senior Western or Senior General Performance Judge.
2. EC-sanctioned Bronze and Silver competitions may use a Recorded or Senior Western or General Performance Judge.
3. Western Judge status allows a Judge to officiate at Equestrian Canada sanctioned Western Division competitions only

ARTICLE F202 GENERAL

1. Recorded Western Judges may officiate at EC Bronze competitions.
2. Senior Western Judges may officiate at Western division classes when offered in EC-sanctioned Bronze and Silver competitions. Silver sanctioned competitions must use Senior Western Judges to officiate. For additional information, see Rules of Equestrian Canada, Section A, General Regulations, Officials.
3. Western judges may officiate at competitions in Canada which are not sanctioned by EC.

ARTICLE F203 CLASSES QUALIFIED TO JUDGE

A Western Judge is qualified to judge:

- Conformation/Halter
- Showmanship at Halter
- Reining
- Western Pleasure
- Western Horsemanship
- Western Riding
- Trail
- Command Class
- Snaffle Bit Futurity
- Western Speed Events

ARTICLE F204 GUEST CARDS

1. Guest cards may be issued to judges recognized by a National Breed Association or who hold Senior status in Arabian, Morgan, Appaloosa, Paint, Pinto or Quarter Horse.
2. Senior General Performance judges may officiate for any Western Division Competition without a guest card.
3. Recorded General Performance judges may officiate without guest cards for any Western Division Bronze competition, and may apply for a guest card to officiate at a Silver competition.
4. Applications for Guest Cards must be made in accordance with the Rules of Equestrian Canada, Section A, General Regulations, Article A1310 Guest Cards, and the Competition Administration Policy (CAP).
5. General Performance and Western judges may judge agricultural fairs and open shows without Guest Card restrictions.

PART TWO GENERAL PERFORMANCE AND WESTERN COMPETITIONS

CHAPTER 3 GENERAL RULES FOR GENERAL PERFORMANCE COMPETITIONS

ARTICLE F301 CLASSIFICATION OF GENERAL PERFORMANCE COMPETITIONS

A General Performance Competition may be conducted as an EC-sanctioned competition with applicable division rules.

ARTICLE F302 EC PROVINCIAL/TERRITORIAL AWARDS

1. EC Provincial or Territorial awards may be established but must be for the General Performance division and identified as eligible for provincial or territorial awards, that are separate from other EC breed/discipline awards.
2. Awards will be based upon total points earned in the respective General Performance classes and other G.P. sections offered at EC-sanctioned competitions only.

ARTICLE F303 COMPETITION REQUIREMENTS

To qualify as a General Performance competition, competitions must have 40% western classes and may offer any of the following classes:

- Western Pleasure*
- Trail Horse*
- Western Riding*
- Command Class*
- General Performance Reining*
- Western Speed Events*
- General Performance Hunter
- General Performance Hunter Hack
- General Performance Jumper
- General Performance Hunter Under Saddle
- General Performance Hack Classes
- General Performance Showmanship at Halter*
- General Performance Hunt Seat Equitation
- General Performance Western Horsemanship*
- Breeding/Halter classes

*Denotes Western class

Note: All competitors under the age of 18 years as of January 1 of the calendar year must wear approved protective headgear* at all times while mounted at the event location.

* (See Glossary, Section A – Headgear Standards).

CHAPTER 4

GENERAL RULES FOR WESTERN COMPETITIONS

ARTICLE F401 CLASSIFICATION OF WESTERN COMPETITIONS

A Western Competition may be conducted as an EC-sanctioned competition with applicable division rules.

ARTICLE F402 COMBINED COMPETITIONS

1. Competitions may offer a Western Division in conjunction with any other EC division (i.e. breed, jumper, dressage), but each division must be run according to its applicable EC division rules.
2. Fees for combined competitions licensed as EC national competitions will be based upon the total prize money offered in all divisions.

ARTICLE F403 EC PROVINCIAL/TERRITORIAL AWARDS

1. EC Provincial or Territorial awards may be established but must be for the Western division in combination with any other GP sections that may be offered in a province or territory and identified as eligible for provincial or territorial awards, and that are separate from other EC breed/discipline awards.
2. Awards will be based upon total points earned in the respective General Performance Western classes and other G.P. sections offered at EC-sanctioned competitions only.

ARTICLE F404 COMPETITION REQUIREMENTS

To qualify as a Western competition, competitions may offer any of the following classes:

- Conformation/Halter (All Sexes)
- Western Pleasure
- Western Horsemanship
- Showmanship at Halter
- Western Riding
- Trail Horse
- Reining
- Snaffle Bit Classes
- Speed Events

Note: All competitors under the age of 18 years as of January 1 of the calendar year must wear approved protective headgear* at all times while mounted at the event location.

* (See Glossary, Section A – *Headgear Standards*).

CHAPTER 5
GENERAL TACK AND EQUIPMENT RULES FOR GENERAL
PERFORMANCE & WESTERN COMPETITIONS

ARTICLE F501 TACK AND EQUIPMENT

1. For all classes, the judge or steward may prohibit the use of any bit or equipment they consider inhumane, unsafe, or would tend to give a horse/rider an unfair advantage.

ARTICLE F502 HEADGEAR AND FALLS

1. See EC Rules, Section A: General Regulations, A101 Accidents and Return to Sport and EC Rules, Section A: General Regulations, A905 Headgear.
2. Approved protective headgear with safety harness permanently affixed to the approved protective headgear is compulsory for everyone riding over fences anywhere on the competition grounds. Junior riders under the age of 18 years as of January 1 of the current year must wear approved protective headgear* at all times while mounted at the event location

*See Section A General Regulations Glossary “Headgear Standards”. Approved protective headgear must be properly fitted and securely fastened.

3. Approved protective headgears must display the approval seal.

PART THREE WESTERN PERFORMANCE CLASSES

CHAPTER 6 WESTERN PERFORMANCE CLASSES

ARTICLE F601 WESTERN TERMINOLOGY

The following terminology shall apply in EC Western division classes whenever a specific gait is called for:

1. The walk is a natural, flat footed, four-beat gait. The horse must move straight and true at the walk. The walk must be alert, with a stride of reasonable length in keeping with the size of the horse.
2. The jog is a smooth, ground covering two-beat diagonal gait. The horse works from one pair of diagonals to the other pair. The jog should be square, balanced and with straight, forward movement of the feet. Horses walking with their back feet and trotting on the front are not considered performing the required gait. When asked to extend the jog, the horse moves out with the same smooth way of going.
3. The lope is an easy, rhythmical three-beat gait. Horses moving to the left should lope on the left lead. Horses moving to the right should lope on the right lead. Horses traveling at a four-beat gait are not considered to be performing at the proper lope. The horse should lope with a natural stride and appear relaxed and smooth. The horse should be ridden at a speed in keeping with his natural way of going.

ARTICLE F602 AGE GROUPS

1. All ages are of January 1.
2. Unless otherwise specified, age group limits for Junior/Youth events may be set by competition management. It is recommended that where there are large classes, they may be divided into age groups to provide equal competitive advantage.
 - a) If there is to be one class, undivided, the age group is to be 18 years and under.
 - b) If there are two classes, the age division must be:
 - 13 years and under
 - 14 years through 18 years
 - c) If there are three classes, the age divisions must be:
 - 11 years and under
 - 12 years through 14 years
 - 15 years through 18 years
3. Age groups may be combined at a competition (at the discretion of the judge, competition management and the unanimous consent of all the competitors involved in a class) only if there are two or less entries in one or both age groups to be combined. However, the 11 year and under age group may never be combined with the 15 through 18 years group.
4. Open Senior/Adult classes may be offered in conjunction with the Youth/Junior.

ARTICLE F603 YOUTH/JUNIOR AND AMATEUR COMPETITORS

1. A Youth/Junior Western competitor is any rider who has not passed his/her 19th birthday as of January 1st of the current calendar year. This rule will apply to all Western Pleasure rules in Section F and Section A relating to the age of a youth/junior.
2. A person competing in EC amateur classes must hold a valid EC Sport Licence, have a current amateur card and adhere to the following guidelines:
 - a) An EC amateur may not accept remuneration for training a horse or for showing a horse at any EC-sanctioned competition. Refer to Section A General Regulations, Amateur Competitors and Section A Glossary for definition of “Remuneration”.
 - b) An EC amateur may not train or show a horse, or instruct a rider or driver, when remuneration for this activity will be given to a corporation or farm which he or she, or his or her family, owns or controls.
 - c) An EC amateur may not act as an agent nor accept commissions for the sale, purchase and/or lease of a horse.
 - d) EC amateurs may not use their name, photograph or any form of personal association as a horse person in connection with any advertisement or article sold without the approval and signature of EC (i.e. product endorsement or advertisement of their activity as a coach).
 - e) An EC amateur may not enter into any form of sponsorship agreement without EC approval.

ARTICLE F604 ENTRIES

1. A horse shall not be allowed to compete unless proper entry is made, and both horse and rider have fulfilled all the rules required. Entries shall not be accepted after a class has officially started.
2. A competitor may enter one or more horses in a class but each horse may have only one rider per class. In individual working events (reining, western riding, speed events), a rider may ride up to three entries, however a horse can only be entered once in each class at a competition. If there is an elimination, each horse must be ridden in the actual class by the same rider who rode it in the elimination.
3. At the discretion of the competition committee, cross-entries between Youth/Junior and Senior/Open divisions may be limited.
4. No Stallion may be exhibited or handled by anyone under the age 18 years of age, anywhere on the competition grounds.
5. A Junior horse is five years old and younger as of January 1st of the current year.
6. A Senior horse is six years old and older as of January 1st of the current year.

ARTICLE F605 CLASS CONDUCT

1. In performance classes, all horses are to be ridden astride and in showmanship all horses are to be led with a halter. No two-year old may be shown in any performance class prior to July 1 of its two-year old year. Prior to July 1 of its two-year old year, horses may be shown in Showmanship classes.
2. In all performance classes where each entry performs individually, the order of competition shall be determined by drawing lots. Whether or not entries perform individually, all horses entered in a class must be assembled in ample time for judging to start on time and continue without delay. They must remain in readiness unless dismissed by the judge. A tardy competitor may be denied competition.

3. No horse is to be penalized for the manner in which he carries his tail nor for normal response with his tail to cues from his rider or when changing leads. A judge may, at his discretion, penalize a horse for excessive or exaggerated switching or wringing of the tail or for a seemingly "dead" tail that merely dangles between the legs and does not show normal response.
4. In all classes where backing is required, the judge may, at his discretion, require the backing of only the finalists in the class.
5. In all classes where horses are worked on the rail (i.e. pleasure, horsemanship etc.) the judge shall not call the horses off the rail to place the class at the canter or lope.
6. In all performance classes that are judged on the rail horses may be asked to reverse at the walk or jog at the discretion of the judge, but shall not be asked to reverse at the lope.
7. The management of any competition shall determine whether or not an elimination is necessary, the number of go-rounds to be held, and the number of horses to be shown at each performance.
8. The final placing of each horse is to be determined by totaling his scores in the finals plus elimination and/or go-rounds.
9. No class is complete until all ties through point earning places are broken. If a tied competitor, or competitors, is disqualified in the runoff, he/she is not to be placed any lower than the lowest position for which she/he was tied. Competitors disqualified during the first run are not considered to be tied for a place even if there are fewer than six different entries in the class.
10. Reruns will not be allowed in instances of competitor equipment failure. When competitor equipment failure causes a delay or a run to be discontinued, the judge will eliminate the entry.
11. Competition arenas must have a safe gate or door that will open and shut.
12. In trail, it is permissible to change hands to work an obstacle.
13. It is mandatory that Trail, Ranch Trail, Showmanship, Horsemanship and Reining patterns be posted one hour before class time. Judges are responsible to approve all patterns and courses prior to posting. It is up to his/her discretion as to who will design patterns or courses.
14. Junior horses (five years old and younger) competing in western pleasure, reining, western riding, trail and western horsemanship that are shown with a hackamore or snaffle bit may be ridden with two hands on the reins.
15. Senior horses (six years old and older) competing must be shown in a suitable western curb bit and be ridden with one hand.
16. Any horse of any age, shown in any separate novice level junior/youth or novice level amateur class may be shown in a snaffle and ridden with two hands.
17. The hand is to be around the reins; index finger only between split reins is permitted. In any recognized performance class, the judge shall have the authority to require the removal or alteration of any piece of equipment or accoutrement which, in his opinion, is unsafe and/or would tend to give a horse an unfair advantage and/or which he/she believes to be inhumane.
18. The score in the eliminations or go-rounds, and the score of each horse in the finals, or, the score in the finals only will determine the final; consistency of performance to be recognized as a major factor.

ARTICLE F606 ELIMINATION

1. In all classes, unless otherwise specified, any rider and/or horse that falls during performance is automatically eliminated. A rider is considered to have fallen

when he or she is not astride. A horse has fallen when both the shoulder and haunch touch the ground.

2. Anytime a horse is bleeding at the mouth or if ridden with a hackamore and has an open, raw, or bleeding sore that comes in contact with the hackamore, the horse must be eliminated.
3. It is mandatory that competition management issue competitor numbers for each horse entered. Furthermore, failure by competitor to wear correct number(s) in a visible manner will result in elimination.
4. In any class requiring equipment, such as trail class, pole bending etc., competitors must not use the competition's equipment for practice before the class begins, without permission from show management, on penalty of elimination. However, they may use other equipment to practice, if such is available.

ARTICLE F607 CHAMPIONSHIPS

Championships shall be based on an accumulated points basis. The number of points awarded depends on the number of horses that competed in each class. Example: 10 horses - 2 points to the first-place horse, 1 point to the second.

ARTICLE F608 AWARDS

Points towards awards shall be calculated based upon the following schedule:

No. Horses in Class	1st	2nd	3rd	4th	5th	6th	7th	8th	9th	10th
3-4	1/2									
5-9	1	1/2								
10-14	2	1	1/2							
15-19	3	2	1	1/2						
20-24	4	3	2	1	1/2					
25-29	5	4	3	2	1	1/2				
30-34	6	5	4	3	2	1	1/2			
35-39	7	6	5	4	3	2	1	1/2		
40-44	8	7	6	5	4	3	2	1	1/2	
45 or more	9	8	7	6	5	4	3	2	1	1/2

CHAPTER 7

WESTERN EQUIPMENT AND ATTIRE

ARTICLE F701 APPROVED PROTECTIVE HEADGEAR

Adult riders may wear Western hats for competition: however, approved protective headgear* may be worn without penalty and is strongly recommended for safety. Junior riders under the age of 18 years as of January 1 of the current year must wear approved protective headgear* at all times while mounted at the event location.

* See Section A General Regulations Glossary "Headgear Standards". Approved protective headgear must be properly fitted and securely fastened.

ARTICLE F702 WESTERN ATTIRE

Competitors must wear appropriate western attire, including a shirt with long sleeves and a collar, western hat and cowboy boots. Boots/shoes worn while riding anywhere on the competition grounds must have a distinguishable heel. Any competitor may wear approved protective headgear in any division or class without penalty from the judge, and is strongly recommended for safety. The hat must be on the rider's head when the competitor enters the arena. Spurs and chaps are optional. Judges, at their discretion, may authorize adjustment to attire due to weather related conditions. Adjustments to tack and attire for valid medical reasons are permitted provided the EC Steward is notified prior to the class.

ARTICLE F703 WESTERN TACK

1. References to hackamore mean the use of a flexible, braided rawhide or leather, or rope bosal, the core of which must be rawhide. Absolutely no rigid material will be permitted under the jaws, regardless of how padded or covered. Horsehair bosals are prohibited. This rule does not refer to a mechanical hackamore.
2. References to snaffle bits in western performance classes are to the conventional O-ring, egg-butt or D-ring with a ring no larger than 4" (100 mm). The inside circumference of the ring must be free of rein, curb or headstall attachments which would provide leverage. The mouthpiece should be round, oval or egg-shaped, smooth and unwrapped metal. It may be inlaid, but smooth or latex-wrapped. The bars must be a minimum of 5/16" (8 mm) in diameter, measured 1" (25 mm) in from the cheek with a gradual decrease to center of the snaffle. The mouthpiece may be two or three pieces. A three-piece, connecting ring of 1" to 1-1/4" (25 mm to 32 mm) or less in diameter, or a connecting ring of 1-1/4" (32 mm) or less in diameter, or a connecting flat bar of 3/8" to 3/4" (10 mm to 20 mm) measured top to bottom, with a maximum length of 2" (50 mm), which lies flat in the horse's mouth is acceptable.
3. References to a bit in western performance classes mean the use of a curb bit that has a solid or broken mouthpiece, has shanks and acts as leverage. All curb bits must be free of mechanical device and should be considered a standard western bit. A description of a legal, standard western bit includes:
 - a) 8-1/2" (215 mm) maximum length shank to be measured as indicated in the diagram at the end of this article. Shanks may be fixed or loose.
 - b) Concerning mouthpieces, bars must be round, oval or egg shaped, smooth and unwrapped metal of 5/16" to 3/4" (8 mm to 20 mm) in diameter, measured 1" (25 mm) from the cheek. They may be inlaid, but must be smooth or latex wrapped. Nothing may protrude below the mouthpiece

- (bar), such as extensions or prongs on solid mouthpieces. The mouthpiece may be two or three pieces. A three-piece, connecting ring of 1-1/4" (32 mm) measured top to bottom with a maximum length of 2" (50 mm) which lies flat in the horse's mouth is acceptable.
- c) The port must be no higher than 3-1/2" (90 mm) maximum, with rollers and covers acceptable. Broken mouthpieces, half-breeds and spades are standard.
 - d) Slip or gag bits, and donut and flat polo mouthpieces are not acceptable.
4. When a curb bit is used, a curb strap or curb chain is required and must be at least 1/2" in width, lie flat against the jaw, and be free of bars, wire, and/or twists. No wire, rawhide, metal or other substance can be used in conjunction with or as part of the leather chin strap, or curb chains. Rounded, rolled, braided or rawhide curb straps are prohibited. A lip strap is permissible. A broken strap or chain is not necessarily cause for disqualification. Optional leather strap attached below the reins on a snaffle bit is acceptable.
 5. Except for hackamore/snaffle bit classes, junior horses shown with hackamore/snaffle bit and separate novice level junior/youth or novice level amateur classes, only one hand may be used on the reins, and the hand must not be changed. The hand is to be around the reins, index finger only between split reins is permitted. Violation of this rule is an automatic disqualification in all western performance classes, except ranch riding and ranch trail, where it is an automatic off-pattern penalty. In trail, ranch trail, and ranch riding, it is permissible to change hands to work an obstacle.
 6. Whenever this division refers to Romal, it means an extension of braided material attached to closed reins.
 - a) This extension is to be allowed to be carried in the free hand with a 16 inch (40 mm) spacing between the reining hand and the free hand holding the romal.
 - b) The romal is not to be used forward of the cinch or used to signal or cue the horse in any way. Any infraction of this rule shall be penalized severely by the judge.
 - c) When using romal reins, the rider's hand shall be around the reins with the wrists kept straight and relaxed, the thumb on top and the fingers closed lightly around the reins.
 - d) No finger between the reins is permitted. The free hand may be used to adjust the rider's length of rein while working except in reining. Use of the free hand while holding the romal to alter the tension or length of the reins from the bridle to the reining hand is considered to be the use of two hands and a score of zero (0) will be applied, except during the hesitation or settling of the horse.
 - e) Junior horses competing in junior or novice level youth/ amateur any age western pleasure, western horsemanship, reining, western riding and trail that are shown with a hackamore or snaffle bit may be ridden with two hands on the reins.
 7. In all classes, horses will be shown in a western stock saddle, Australian stock saddles are not permitted. Silver equipment will not count over a good working outfit. Horses five years and under may be shown in a snaffle bit, hackamore or curb bit, half breed or spade bit.
 8. Optional equipment:
 - a) Rope or riata. If used, the rope or riata must be coiled and attached to saddle.
 - b) Hobbles - attached to saddle.

- c) Tapaderos
 - d) Protective boots, leg wraps and bandages are allowed in reining, western speed events, ranch riding and western horsemanship.
 - e) Tie-downs for speed events
 - f) Running martingales for speed events
 - g) Spurs - not to be used forward of the cinch
9. Prohibited Equipment:
- a) Protective boots of any description, leg wraps and bandages are prohibited in western pleasure, trail, ranch trail, halter, western riding, ranch riding, working western rail, and showmanship.
 - b) Any chinstrap narrower than one half inch
 - c) Martingales and draw reins, except for speed events. However, these cannot have any bare metal in contact with the horse's head.
 - d) Nosebands and tie downs, except for speed events
10. Please see Reining and Western Pleasure sections of this rulebook for special rules regarding the use of hackamores and snaffle bits.
11. In speed events, western type equipment must be used. Use of a hackamore (including mechanical hackamores) or other type of headstalls is the optional choice of the competitor. However, the judge may prohibit the use of bits or equipment he/she may consider severe.
- a) Optional Equipment:
 - (i) Tie-downs
 - b) Prohibited equipment:
 - (i) Jerk lines
 - (ii) Tack collars
12. Any time a horse's mouth is tied or fastened in a performance class, it shall be eliminated.
13. Any time a horse's mouth is bleeding in a performance class, it must be eliminated.
14. The judge or steward may prohibit the use of any bit or equipment they consider inhumane or would tend to give a horse/rider an unfair advantage.



WESTERN BITS

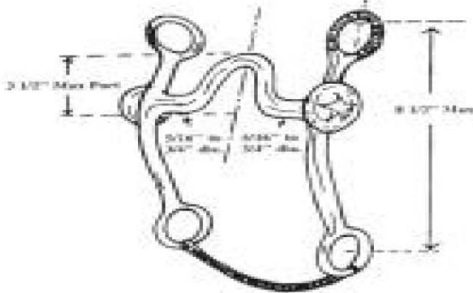

LEGAL BIT

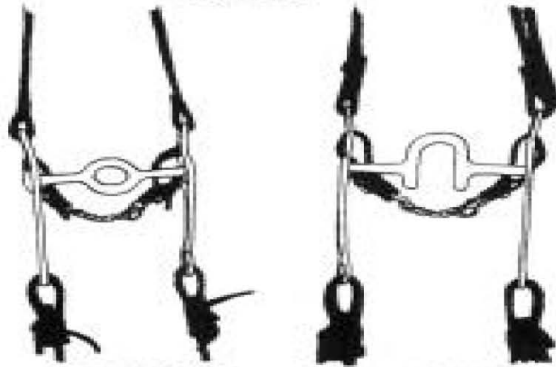

DONUT BIT

PRONG BIT

ILLEGAL BITS

CHAPTER 8

WESTERN PLEASURE

ARTICLE F801 GENERAL

A good pleasure horse has a free-flowing stride of reasonable length in keeping with his conformation. He should cover a reasonable amount of ground with little effort. Ideally, he should have a balanced, flowing motion, while exhibiting correct gaits that are of the proper cadence. The quality of the movement and the consistency of the gaits is a major consideration. He should carry his head and neck in a relaxed, natural position, with his poll level with or slightly above the level of the withers. He should not carry his head behind the vertical, giving the appearance of intimidation or be excessively nosed out, giving a resistant appearance. His head should be level with his nose slightly in front of the vertical having a bright expression with his ears alert. He should be shown on a reasonably loose rein, but with light contact and control. He should be responsive, yet smooth, in transitions when called for. When asked to extend, he should move out with the same flowing motion. Maximum credit should be given to the flowing, balanced and willing horse that gives the appearance of being fit and a pleasure to ride.

ARTICLE F802 CLASSES

A competition may have up to two western pleasure classes.

1. If two western pleasure classes are to be held at a competition, they shall be the following:
 - a) Senior western pleasure (six years old or older, shown with a bit)
 - b) Junior western pleasure (five years old and younger, shown with a bit, hackamore or snaffle bit)
2. If only one western pleasure class is to be held at a competition, it shall be the following:
 - a) Western pleasure-all ages (horses six years old and older must be shown in bit). Horses five years old and younger may be shown in either bit, hackamore or snaffle bit.

ARTICLE F803 CONDUCT

1. This class will be judged on the performance, condition and conformation of the horse; however, a minimum of 20% of the judging shall be placed on condition and conformation.
2. Horses must work both ways of the ring at all three gaits to demonstrate their ability with different leads. At the option of the judge, horses may be asked to extend the walk, jog, or lope, one or both ways of the ring. The judge may ask all or just the top 12 horses to extend at the jog, however, never more than the top 12 horses may be asked to extend at the lope. Riders should sit at the extended jog. Horses are required to back easily and stand quietly.
3. Horses may be required to reverse at the walk or jog at the discrimination of the judge, but shall not be asked to reverse at the lope.
4. Judge may ask for additional work of the same nature from any horse. He/she is not to ask for work other than that listed above.
5. Rider shall not be required to dismount except in the event judge wishes to check equipment.
6. Junior Western Pleasure horses shown with a hackamore or snaffle bit, in which reins shall be held as per Article F703.4. When a romal is used, it shall be carried as per Article F703.5
7. Faults to be scored according to severity:

- a) Breaking gait
 - b) Being on wrong lead
 - c) Excessive speed (any gait)
 - d) Excessive slowness in any gait, loss of forward momentum
 - e) Failure to take the appropriate gait when called for
 - f) Touching horse or saddle with free hand
 - g) Opening mouth excessively
 - h) Stumbling or falling
 - i) Use of spurs or romal forward of the cinch
 - j) A horse that appears sullen, dull, lethargic, emaciated, drawn or overly tired
 - k) Excessive nosing out
 - l) Quick choppy or pony stride
 - m) If reins are draped to the point that light contact is not maintained
 - n) Head carried too high
8. Faults which may be cause for disqualification:
- a) Changing hands or two hands on reins except with a hackamore or a snaffle.
 - b) More than one finger between reins.
 - c) Head carried too low, tip of ear below the withers consistently for more than five strides.
 - d) Over flexing or straining neck in head carriage so the nose is carried behind the vertical consistently for more than five strides.

CHAPTER 9 TRAIL HORSE

a) ARTICLE F901 DELETED

ARTICLE F902 CONDUCT

1. This class will be judged on the performance of the horse over the obstacles, with emphasis on manners, response to the rider and quality of movement
2. Credit will be given to those horses negotiating the obstacles with style and some degree of speed, providing correctness is not sacrificed. Horses should receive credit for showing attentiveness to the obstacles, to having the capability of picking their own way through course when obstacles warrant it, and to willingly responding to rider cues on more difficult obstacles.
3. Horses shall be penalized for any unnecessary delay while approaching obstacles. Horses with artificial appearance over obstacles should be penalized as should exaggerated standing in stirrups and leaning forward over horse's neck by rider.
4. Riders shall be penalized for obviously cueing their horses on the neck or anywhere forward of the cinch. Except for junior horses shown with hackamore or snaffle bits, only one hand may be used on the reins, except that is permissible to change hands to work an obstacle. While horse is in motion, rider's hand shall be clear of horse and saddle.
5. Horses must not be required to work on the rail. The course must be designed, however, to require each horse to show the three gaits (walk, jog, lope) somewhere between obstacles as a part of its work and quality of movement and cadence should be considered as a part of the maneuver score. While on the line of travel between obstacles, the horse shall be balanced, carrying his head and neck in a relaxed, natural position, with the poll level with or slightly above the withers. The head should not be carried behind the vertical, giving the appearance of intimidation, or be excessively nosed out, giving a resistance appearance.
6. Gaits between the obstacles shall be at the discretion of the judge. A flying lead change does not constitute an obstacle in a trail class. Any lead change or change of gait shall be judged under the scored gaits and way of going judging criteria. A flying lead change cannot be required, but it can be optional.
7. A properly designed course will have natural obstacles normally encountered along a trail. At least six obstacles will be used, three of which will be mandatory and at least three others selected from the approved list. Gait between obstacles shall be at the discretion of the judge. The course to be used must be posted at least one hour before scheduled time of the class. Failure to follow course shall cause elimination.
8. If disrupted, the course shall be reset as each horse has worked. When setting courses, management should keep in mind that the idea is not to trap a horse, or eliminate it by making an obstacle too difficult. If difficult courses are set, junior trail should be less difficult. Enough space must be provided for a horse to jog/trot at least 30 feet, and lope at least 50 feet for the judge to evaluate these gaits.
9. The judge must walk to course and has the right and duty to alter the course in any manner. The judge may remove or change any obstacle he deems unsafe or non-negotiable. If at any time a trail obstacle is deemed to be unsafe by the judge, it shall be repaired or removed from the course. If it cannot be repaired

and horses have completed the course, the score for that obstacle shall be deducted from all previous works for that class. When the distances and spaces are measured between all obstacles, the inside base to inside base measurement of each obstacle considering the normal path of the horse, should be the measuring point.

10. Except for junior horses shown with hackamore or snaffle bit, only one hand may be used on the reins except that it is permissible to change hands to work an obstacle. Hand is to be around reins, index finger only between reins is permitted. When a romal is used it shall be carried as per EC western equipment rules. Horses six years of age or older must be shown in a bit.
11. If disrupted, the course shall be reset after each horse has worked. In the case where combinations of obstacles are used, the course cannot be reset until the competitor finishes the entire course regardless of where any disruption occurs.
12. **SCORING:** Suggested scoring will be on the basis of 0-infinity, with 70 denoting an average performance. Each obstacle will receive an obstacle score that should be added or subtracted from 70 and is subject to a penalty that should be subtracted. Each obstacle will be scored on the following basis, ranging from plus 1½ to minus 1½ ; - 1½ extremely poor, -1 very poor, - ½ poor, 0 correct, ½ good; +1 very good, +1½ excellent. Obstacle scores are to be determined and assessed independently of penalty points. Penalties should be assessed per occurrence as follows:

The following deductions will result:

* A 0 SCORE (DISQUALIFIED) CANNOT PLACE*

DISQUALIFIED 0 – SCORE

- Use of more than one finger between reins
- Use of two hands (except in snaffle bit or hackamore classes designated for two hands) or changing hands on reins; except for junior horses shown with hackamore or snaffle bit, only one hand may be used on the reins, except that it is permissible to change hands to work an obstacle.
- Use of romal other than as outlined in F703.5
- Performing the obstacles incorrectly or other than in specified order
- No attempt to perform an obstacle
- Equipment failure that delays completion of pattern
- Excessively or repeatedly touching the horse on the neck to lower the head
- Fall to the ground by horse or rider
- Failure to enter, exit or work obstacle from correct side or direction, including overturns of more than ¼ turn.
- Failure to follow the correct line of travel within or between obstacles.
- Failure to work an obstacle in any manner other than how it is described by the course.
- Failure to complete obstacle.
- Failure to open and shut gate. (Except for novice level classes where they place below those who complete the course correctly.)
- Riding outside designated boundary marker of the arena or course area.
- Third refusal
- Failure to demonstrate correct lead or gait, if designated
- **Faults that occur on the line of travel between obstacles, which will be cause for disqualification, except in novice amateur or novice youth classes, which shall be faults scored according to severity:**
 - (1) head carried too low (tip of ear below the withers consistently)
 - (2) over-flexing or straining neck in head carriage so the nose is carried behind the vertical consistently.

½ POINT

- Each tick of log, pole, cone or obstacle

1 POINT

- each hit, bite, or stepping on a log, cone, plant or any component of the obstacle
- incorrect or break of gait at walk or jog for two strides or less
- Both front or hind feet in a single-strided slot or space
- Skipping over or failing to step into required space
- Split pole in lope-over
- Failure to meet the correct strides on trot over and lope over log obstacles.

3 POINTS

- Break of gait at walk or jog for more than 2 strides
- Out of lead or break of gait at lope (except when correcting an incorrect lead)
- Knocking down an elevated pole, cone, barrel, plant obstacle, or severely disturbing an obstacle.
- Stepping outside the confines of, falling, or jumping off or out of an obstacle with one foot.

5 POINTS

- Holding saddle
- Dropping slicker or object required to be carried on course
- First refusal, balk, or attempting to evade an obstacle by shying or backing more than 2 strides away
- Second refusal
- Letting go of gate or dropping rope gate
- Stepping outside the confines of, falling, or jumping off or out of an obstacle with more than one foot
- Blatant disobedience (kicking out, bucking, rearing, striking)
- Use of either hand to instill fear or praise

The trail course to be used must be posted at least one hour before scheduled starting time of the class.

ARTICLE F903 MANDATORY OBSTACLES

1. Opening, passing through, and closing gate. (Losing control of gate is to be penalized.) Use a gate which will not endanger horse or rider. If the gate has a metal, plastic or wooden support bar under the opening, competitors must work the gate moving forward through it.
2. Ride over at least four logs or poles. These can be in a straight line, curved, zigzag or raised. The space between the logs is to be measured and the path the horse is to take should be the measuring point. All elevated elements must be placed in a cup, notched block, or otherwise secured so they cannot roll. The height should be measured from the ground to the top of the element. Spacing for walkovers, trot overs, and lope overs should be as follows or increments thereof.
 - a) The spacing for walkovers shall be 40 to 60 cm (20 – 24 inches) and may be elevated to 30cm (12”). Elevated walkovers should be set at least 55.88cm (22 inches) apart.
 - b) The spacing for trot overs shall be 91.44cm – 1.04m (36 to 39 inches) and may be elevated to 20.32cm (8 inches).
 - c) The spacing for lope overs shall be 1.8 – 2.8 meters (six – 6.5 feet) or in increments thereof, and may be elevated to 20.32cm (eight inches)).

3. Backing obstacle.
 - a) Backing obstacles to be spaced a minimum of 71.12cm or 28 inches. If elevated, 76.20 or 30 inches spacing is required. Entrants cannot be asked to back over a stationary object such as a wooden pole or metal bar.
 - b) Back through and around three markers.
 - c) Back through L, V, V straight or similar shaped course. Poles may be elevated no more than 60.96cm (24 inches).
4. Optional obstacles, but not limited to:
 - (i) Water hazard (ditch or small pond). No metal or slick bottom-boxes will be used.
 - (ii) Serpentine obstacles at walk or jog. Spacing to be minimum of 1.82m (6 feet) for jog.
 - (iii) Carry object from one part of arena to another. Only objects which reasonably might be carried on a trail ride may be used.
 - (iv) Ride over wooden bridge. Bridge should be sturdy and safe. Suggested minimum width shall be 91.44cm (36 inches) wide and at least 1.82m (6 feet) long.
 - (v) Put on and remove slicker.
 - (vi) Remove and replace materials from mailbox.
 - (vii) Side pass may be elevated to 30.48cm (12 inches) maximum.
 - (viii) An obstacle consisting of four logs or rails, each 1.52 – 2.13m (6 to 7 feet) long, laid in a square. Each competitor will enter the square by riding over log or rail as designated. When all four feet are inside the square, rider should execute a turn, as indicated, and depart.
 - (ix) Any other safe and negotiable obstacle that may be reasonably expected to be encountered on a trail ride and meets the approval of the judge may be used.
 - (x) A combination of two or more of any obstacle is acceptable.
5. Prohibited obstacles:
 - (i) Tires
 - (ii) Animals
 - (iii) Hides
 - (iv) PVC pipe
 - (v) Dismounting
 - (vi) Jumps
 - (vii) Rocking or moving bridges
 - (viii) Water box with floating or moving parts
 - (ix) Flames, dry ice, fire extinguisher, etc.
 - (x) Logs or poles elevated in a manner that permits such to roll.
 - (xi) Plastic / tarps
 - (xii) Ground ties

MANDATORY OBSTACLES (choose 3)	OPTIONAL OBSTACLES (choose 3+)
Gate - (open, pass through & close)	Water hazard - (ditch or small pond)
Minimum of four logs/poles with following spacing:	Carrying an object
	Bridge

- walk: 15 - 24 in. ground level 22 in. if elevated - jog: 3 - 3½ ft. - ground level not elevated - lope: 6 - 6½ ft. - ground level not elevated	Walk or jog serpentine - 6 ft. space for jog
	Another object or combination that could be expected on a trail ride
Backing obstacle with a minimum spacing of 25 in. ground level, 30 in. if elevated, OR Back through and around three markers, OR Back through L, V straight or similar shaped course, if elevated must be maximum of 24 in..	Put on/remove sticker
	Mailbox
	Side Pass (maximum 12 in. if elevated)
	Square of logs/rails, each 6 - 7 ft: rider to enter, turn and exit

PROHIBITED OBSTACLES (but not limited to)	
Animals	Tires
Hides	Jumps
PVC Pipe	Fire Extinguishers
Dry Ice	Dismounting
Rocking or Moving Bridge	Water box with floating/moving parts
Logs/Poles elevated that permit them to roll	

Trail Horse Patterns

Back Through and Around Three Markers

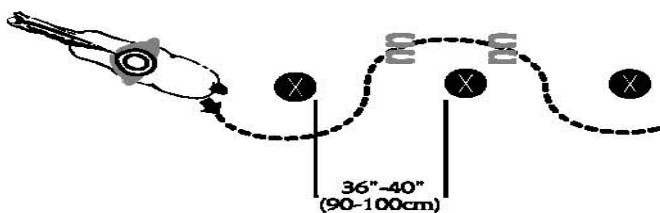
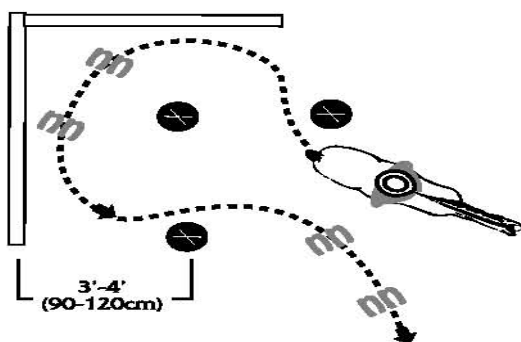
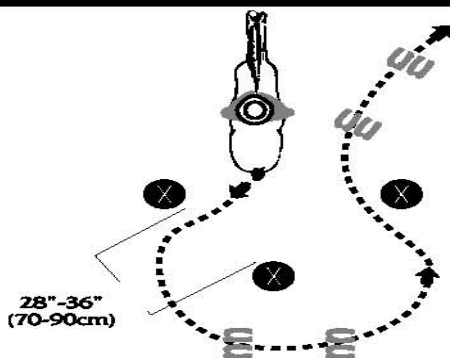

Back Through and Around Three Markers

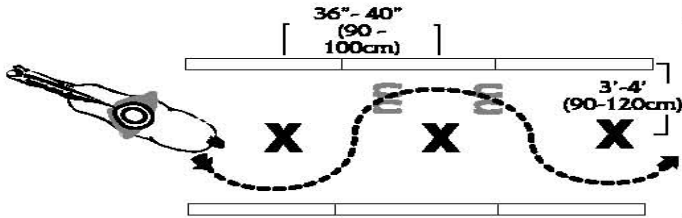

Trot Overs, Lope Overs

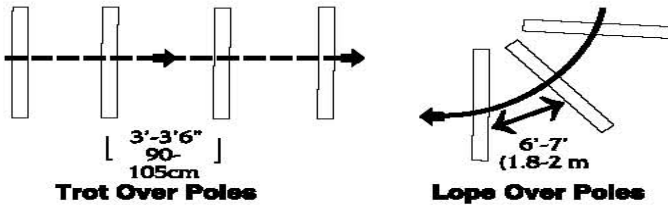

Note: Lop Over Poles revised: 6-6½ feet ground level, not elevated.

Walk Overs

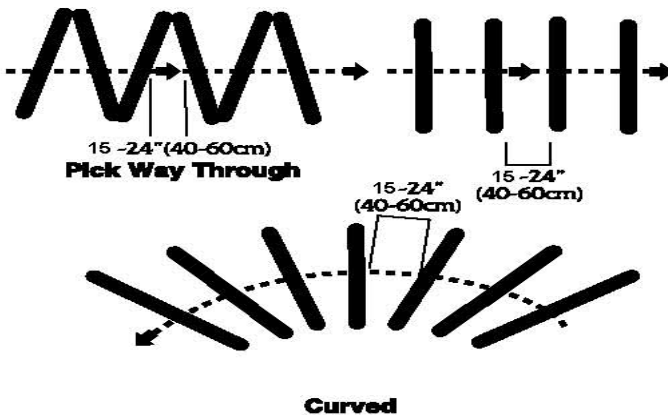

Trot Overs, Lope Overs & Walk Overs

Can use
Walk Overs, Trot Overs
& Lope Overs In One Class

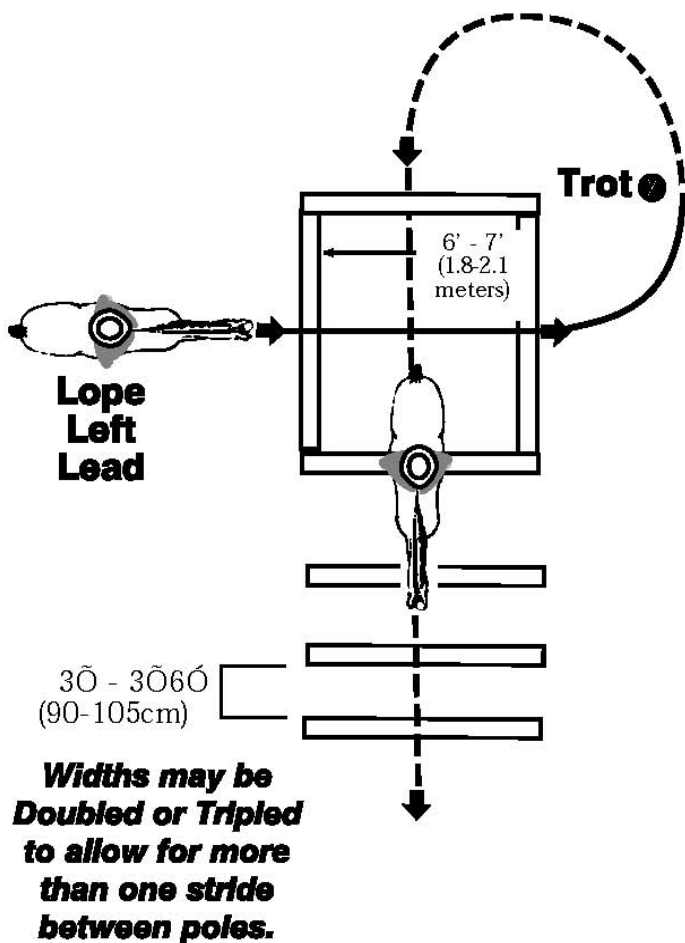

Variations of Sidepass

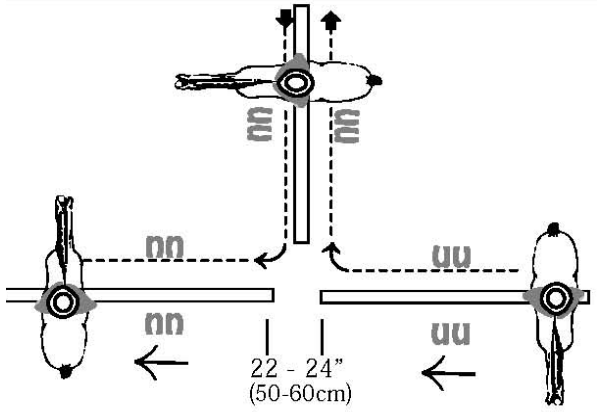

Variations of L Back Through

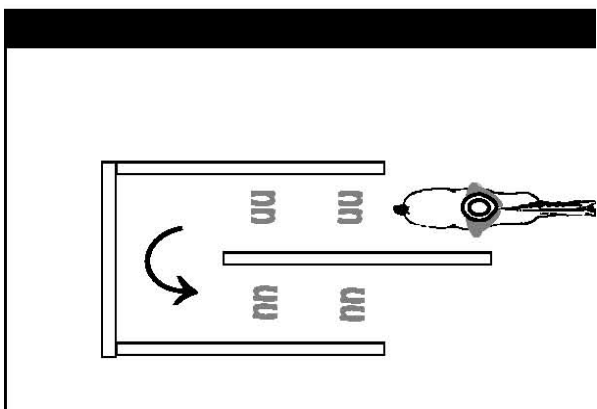
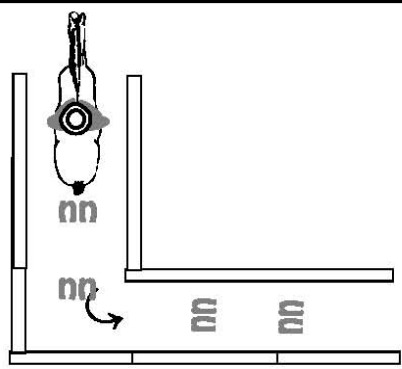

Sample Trail Pattern

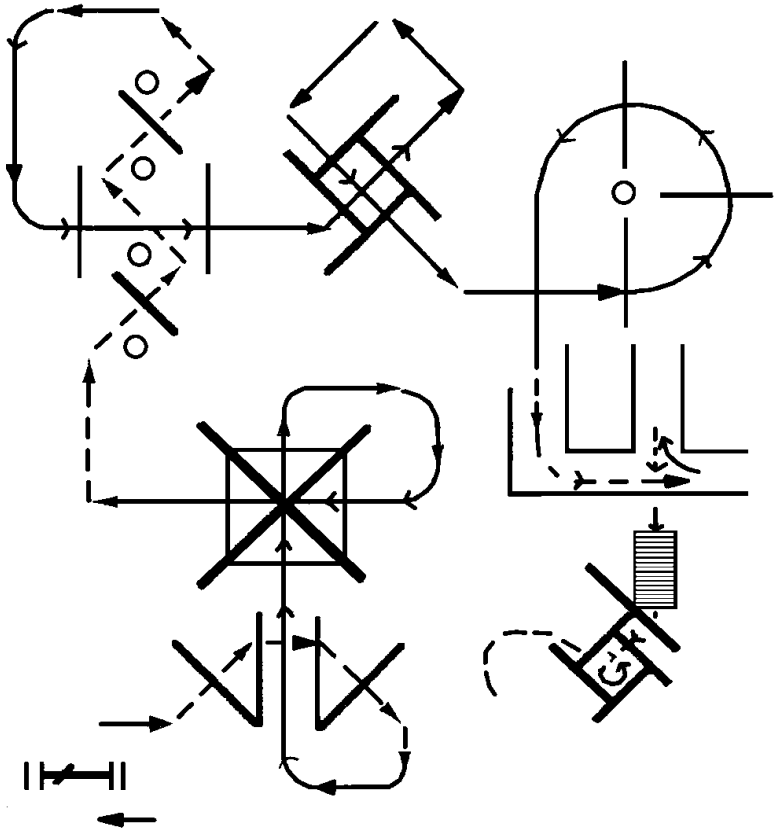

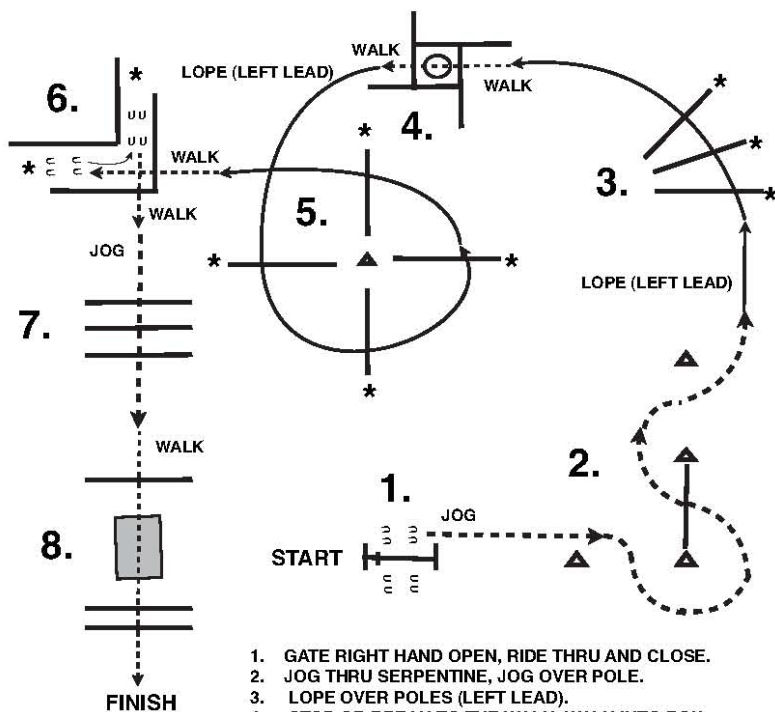

1. GATE RIGHT HAND OPEN, RIDE THRU AND CLOSE.
2. JOG THRU SERPENTINE, JOG OVER POLE.
3. LOPE OVER POLES (LEFT LEAD).
4. STOP OR BREAK TO THE WALK, WALK INTO BOX, 360 TURN EITHER DIRECTION, WALK OUT BOX.
5. LOPE OVER SPOKE (LEFT LEAD).
6. STOP OR BREAK TO THE WALK, WALK INTO "L" BACK AROUND CORNER, WALK OUT "L".
7. JOG OVER POLES.
8. STOP OR BREAK TO THE WALK, WALK OVER POLES AND OVER BRIDGE.

CHAPTER 10 WESTERN RIDING

ARTICLE F1001 GENERAL

Western Riding is an event where the horse is judged on quality of gaits, lead changes at the lope, response to the rider, manners and disposition. The horse should perform with reasonable speed, and be sensible, well-mannered, free and easy moving.

ARTICLE F1002 CONDUCT

1. Credit shall be given for and emphasis placed on smoothness, even cadence of gaits (i.e. starting and finishing pattern with the same cadence), and the horse's ability to change leads precisely and easily rear and front at the centre point between markers. Gaits are to be performed as described in Article F601, Western Terminology. The horse should have a relaxed head carriage showing response to the rider's hands with a moderate flexing at the poll. Tail carriage shall be judged as detailed in Article F605.3, Class Conduct. The horse should cross the log both at the jog and the lope without breaking gait or radically changing stride.
2. The judge will select one of the three patterns to be performed. The judge is responsible for the pattern being correctly set. On the pattern:
 - a) The eight small circles represent pylon markers, which are recommended. These should be separated by a uniform measured distance of not less than 30 feet or more than 50 feet on the side with five markers (see diagram). It is recommended that markers be set a minimum of 15 feet from the fence.
 - b) The rectangle represents an obstacle (one small log recommended), minimum of eight feet in length.
 - c) The long or serpentine line indicates the direction of travel and the gaits at which the horse is to move. The dotted line (...) indicates walk, the dash line (- - - -) jog. And the solid line (——) lope.
3. Except for junior horses shown with a hackamore or snaffle bit, only one hand must be used and not be changed, except that it is permissible to change hands when opening gate if the gate is in such a position as to justify the change of hands on the reins. When a romal is used, it shall be carried as per Article F703.5. Senior horses must be shown in a bit.
4. Scoring will be on a basis of 0 to 100 with 70 denoting an average performance. Points will be added or subtracted from maneuvers on the following basis, ranging from plus 1½ points to minus 1½ points, with the following guidelines to be considered: +1½, excellent; +1 very good; +½, good; 0, average; -½, poor; -1, very poor; and 1½, extremely poor.
5. A competitor shall be penalized:
 - a) Five Points:
 - (i) Out of lead beyond the next designated change area.
NOTE: Failures to change, including cross-cantering, at two consecutive changes areas would result in 10 penalty points.
 - (ii) Kicking out
 - (iii) Blatant disobedience
 - (iv) holding saddle.
 - b) Three points:
 - (i) Not performing the specific gait (jog or lope) or stopping when called for in the pattern, within 10 feet of the designated area

- (ii) Break of gait at the lope
 - (iii) Simple change of leads
 - (iv) Out of lead prior to the designated changes from the cone to the previous change area or out of lead after designated change from the cone to the next designated change area
 - (v) Additional lead changes anywhere in pattern (except when correcting an extra change or incorrect lead) in pattern one and three, failure to start the lope within 30 feet after crossing the log at the jog
 - (vi) Break of gait at walk or jog for two or more strides
- c) One Point:
- (i) Break of gait at walk or jog up to two strides
 - (ii) Hitting or rolling log
 - (iii) Out of lead for more than one stride to the cone
 - (iv) Splitting the log (log between the two front or two hind feet) at the lope.
 - (v) Hind legs skipping or coming together
 - (vi) Non-simultaneous lead change
- d) One-half Point:
- (i) Tick or light touch of log
- e) Disqualified 0 Score;
- (i) illegal equipment
 - (ii) willful abuse
 - (iii) off course
 - (iv) knocking over markers
 - (v) completely missing log
 - (vi) major refusal – stop and back more than 2 strides or 4 steps with front legs
 - (vii) major disobedience – rearing, schooling
 - (viii) Failure to start lope prior to cone in pattern # 1
 - (ix) Four or more simple lead changes and /or failure to change leads
 - (x) Overturn of more than 1/4 turn
- f) Credits:
- (i) changes of leads, hind and front simultaneously
 - (ii) changes at designated point
 - (iii) accurate and smooth pattern
 - (iv) even pace throughout
 - (v) easy to guide and control with rein and leg
 - (vi) manners and disposition
 - (vii) conformation and fitness
6. The following characteristics are considered faults and should be judges accordingly in maneuver scores:
- a) Opening mouth excessively
 - b) Anticipating signals or early lead changes
 - c) Stumbling

LOCATION PENALTIES FOR DESIGNATED CHANGE

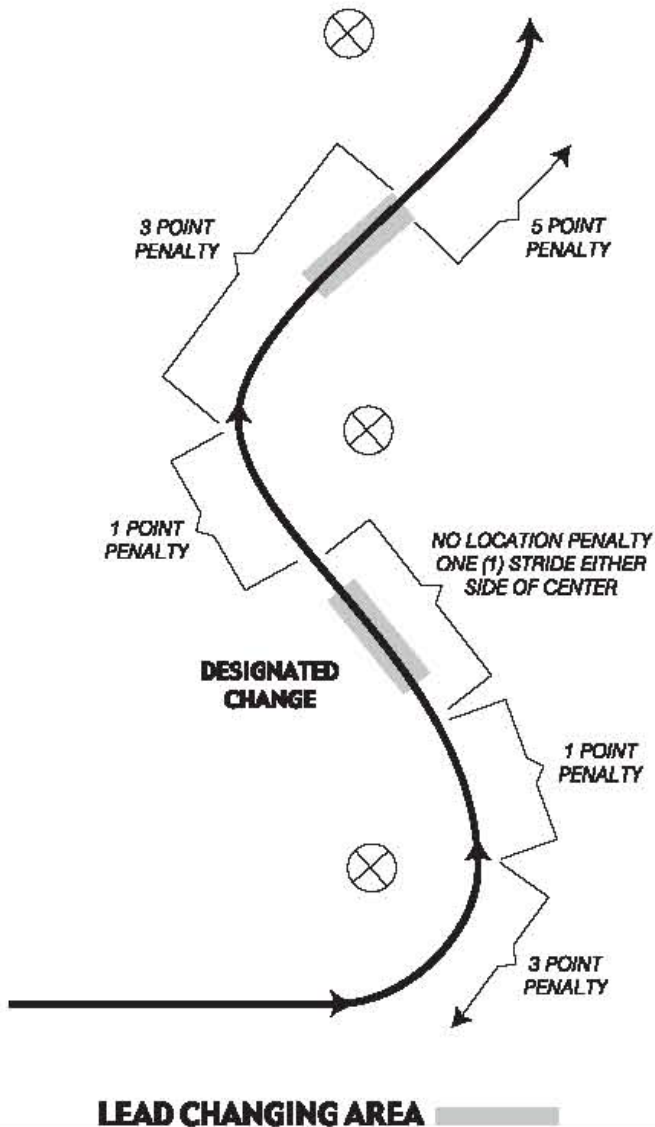

LOCATION PENALTIES FOR DESIGNATED CHANGE

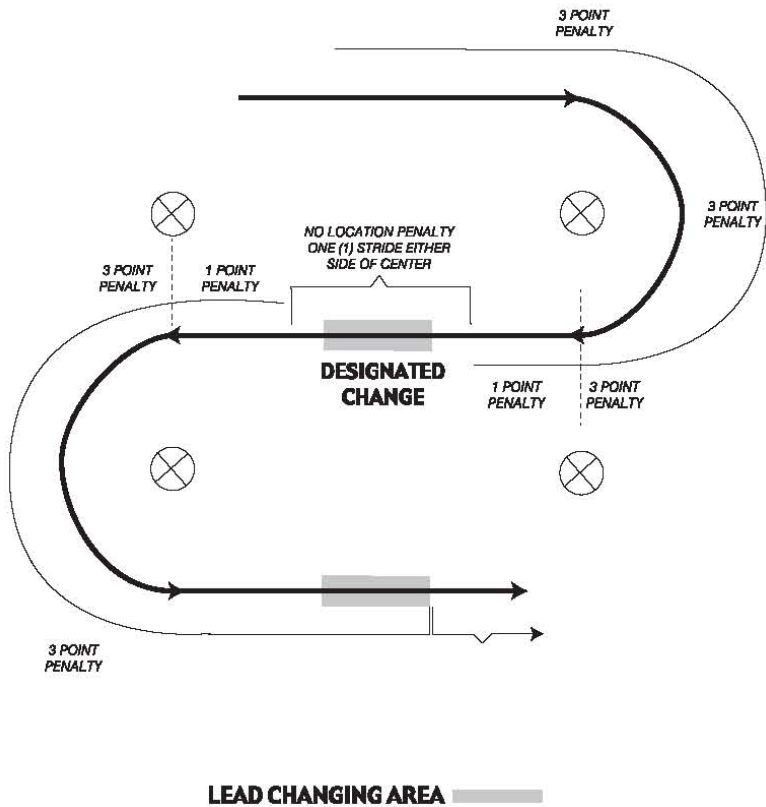

LEVEL 1 WESTERN RIDING PATTERN II

1. Walk at least 15 feet from start cone to the first marker, as drawn, transition to jog, jog over log
2. Transition to the lope left lead
3. First crossing change
4. Second crossing change
5. Third crossing change
6. Circle & first line change
7. Second line change & circle
8. Lope over log
9. Stop & back

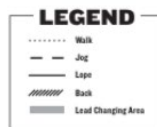
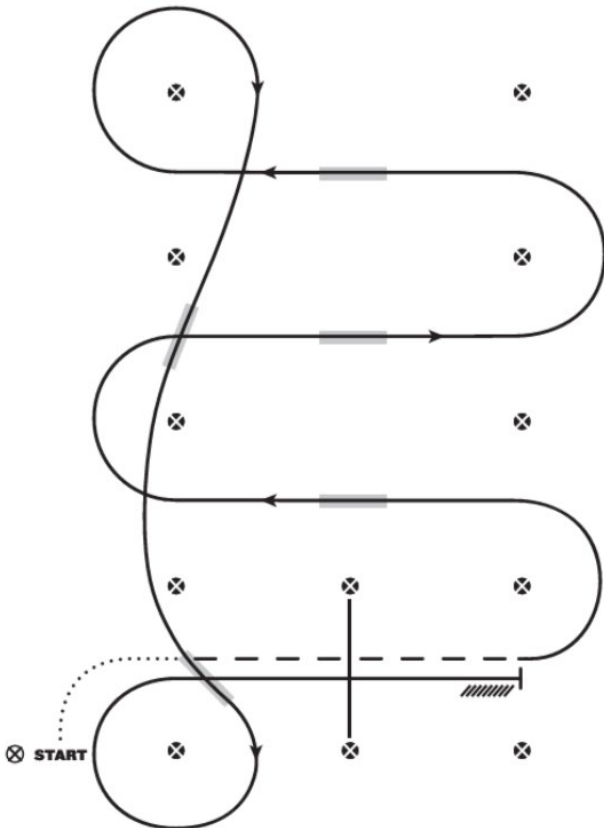

CHAPTER 11 COMMAND CLASS

ARTICLE F1101-GENERAL

The command class is neither a race nor is it a gymkhana event. It is a competition that exhibits the abilities of a well trained, responsive performance horse.

ARTICLE F1102 ATTIRE

Riders must be neatly dressed in suitable western attire as outlined in Chapter 9: Western Riding.

ARTICLE F1103 CONDUCT

1. Entries are eliminated, one at a time at the discretion of the judge as commands are not executed correctly. At no time are horses to be judged individually or one at a time to decide the class. At no time are ring stewards allowed to partake in the judging or placing of the class. The command to stop from the lope or hand gallop can be given only once in each direction.
2. Suggested commands are as follows: stop, jog, lope, reverse (at any gait), backup, 360° turn on the haunches, 180° turn on the forehand, side pass (left and right, counter canter, reverse, flying change of leads (no more than 8 horses), reverse simple change of leads (no more than 8 horses), roll back, walk, etc.
3. Examples of elimination are as follows: failure to execute the command correctly, wrong leads, disunited, excessive speed, breaking gait, hanging up or turning sideways at the back up, circling for better position without being commanded to do so, moving when stopped, etc. At the judge's discretion, entries may be eliminated for poor execution of the command, i.e. taking too long to execute transition from one gait to another, horse opening mouth excessively at the back up, etc.

CHAPTER 12 GENERAL PERFORMANCE REINING

ARTICLE F1201 GENERAL

1. To rein a horse is not only to guide it, but also to control its every movement. The best reined horse should be willingly guided or controlled with little or no apparent resistance and dictated to completely. Any movement on its own must be considered a lack of control. All deviations from the exact written pattern must be considered a lack of or temporary loss of control, and therefore faulted according to severity of deviation. Credit will be given for smoothness, finesse, attitude, quickness and authority in performing the various maneuvers while using controlled speed.
2. Each competitor will perform the required pattern individually and separately. All horses will be judged immediately upon entering the arena, and judging will cease after the last maneuver. Any fault incurred prior to the commencement of a pattern will be scored accordingly.
3. Any approved EC reining pattern, EC para-equestrian pattern, NRHA pattern or Breed pattern may be used and is to be selected by the judge of the class and used by all competitors in the class.
4. Scoring will be on the basis of 0-Infinity, with 70 denoting an average performance.
5. Excess rein may be straightened anytime during the pattern, provided the rider's free hand remains behind the hand. Any attempt to alter tension or length of the reins from bridle to the rein hand is to be considered use of two hands a penalty score of zero will be applied.
6. Equipment checks are to be conducted either by the (call) judge prior to leaving the arena or by the Steward immediately outside the performance arena after the run.

ARTICLE F1202 REINING SCORING GUIDELINES

NEITHER A NO SCORE NOR A 0 SCORE CAN PLACE

NO SCORE

- Infraction of any state or federal law
- **Abuse** of an animal in the show arena and/or evidence that abuse has occurred prior to or during the exhibition of a horse (blood on sides/mouth)
- Use of **illegal equipment**
- Use of illegal bits, bosals or curb straps
- Use of tack collars, tie downs or nosebands
- Use of whips
- Use of any attachment that alters the movement or circulation of the tail
- Failure to dismount and present horse and tack to appropriate judge
- **Disrespect** or misconduct by the competitor
- Judge may excuse any horse at any time while in the arena for unsafe conditions or improper exhibition pertaining to both the horse and/or the rider
- Closed reins are not allowed except as standard romal reins.
- When going to and coming out of a rollback in a pattern requiring a run-around, a rollback that crosses the center line.

'0' SCORE

- Use of more than the index or first finger between reins
- Use of 2 hands (except snaffle bit or hackamore classes) or changing hands

- Use of romal except as outlined in rules
- Failure to complete pattern as outline
- Performing maneuvers out of order
- Inclusion of maneuvers not specified, including but not limited to:
 1. backing more than 2 strides
 2. turning more than 90 degrees
 3. On run in patterns, once beginning a lope a complete stop prior to reaching the first marker. (**EXCEPTION:** a complete stop in the 1st quarter of a circle after a lope departure is not to be considered an inclusion of a maneuver: a 2 point break of gait penalty will apply.)
- Equipment failure
- Balking or refusal of command where the pattern is delayed
- Running away or failing to guide where it becomes impossible to discern if the entry is on pattern.
- Jogging in excess of ½ circle or ½ the length of the arena
- Over spins of more than ¼ turn
- Fall to the ground by horse or rider
- Dropping a rein that contacts the ground
- Failure to have the correct number displayed
- Failure to wear correct western attire

PENALTIES

5 POINTS

- Spurring in front of the cinch
- Use of either hand to instill fear or praise
- Holding saddle with either hand
- Blatant disobedience including kicking, rearing, biting, bucking or striking

2 POINTS

- Break of gait
- Freezing up in spins or rollbacks
- On walk in patterns, loping prior to reaching the centre and/or failure to stop or walk before executing a lope departure.
- On run in patterns, failure to be in a lope prior to reaching the first marker
- If a horse does not completely pass the specified marker before initiating a stop position
- Jogging beyond 2 strides but less than ½ circle or ½ length of the arena
- Out of lead more than one-half turn when rounding end of arena.

1 POINT

- Each time a horse is out of lead
- Penalty for being out of lead on a circle is accumulative for each ¼ circle or any part thereof that the horse is out of lead.
- Over or under spinning up to ¼ turn
- For run-around patterns, failure to be on the correct lead when rounding the end of the arena will be penalized as follows: for half of the turn or less

1/2 POINT

- Delayed change of lead by one stride where the lead change is required by the pattern description.

- Starting a circle at a jog
- Exiting a rollback at a jog up to 2 strides

Over or under spinning up to 1/8 of a turn

For failure to stay 20 feet from the wall when approaching a stop or rollback.

If there is any doubt regarding a penalty, credit goes to the competitor.

MANUEVERS:

- +1 ½ excellent
- +1 very good
- +1/2 good
- 0 average/correct
- -1/2 poor
- -1 very poor
- -1 ½ extremely poor
-

HIERARCHY OF CONCERN:

1. On Pattern
2. Correctness
3. Level of Difficulty

THE WORK:

Credit:

- Authority of execution
- Smoothness
- Finesse
- Quickness
- Speed Control

Discredit:

- Lack of control
- Resistance

SAMPLE REINING PATTERN

1. Run at speed to the far end of the arena past the end marker and do a left rollback - no hesitation.
2. Run to the opposite end of the arena past the end marker and do a right rollback - no hesitation.
3. Run past the center marker and do a sliding stop. Back up to center of the arena or at least ten feet (3 meters). Hesitate.
4. Complete four spins to the right.
5. Complete four and one-quarter spins to the left so that horse is facing left wall or fence. Hesitate.
6. Beginning on the left lead, complete three circles to the left: the first circle large and fast; the second circle small and slow; the third circle large and fast. Change leads at the center of the arena.
7. Complete three circles to the right: the first circle large and fast; the second circle small and slow; the third circle large and fast. Change leads at the center of the arena.

8. Begin a large fast circle to the left but do not close this circle. Run straight up the right side of the arena past the center marker and do a sliding stop at least 20 feet (6 meters) from wall or fence. Hesitate to demonstrate the completion of the pattern. Rider may drop bridle to the designated judge.

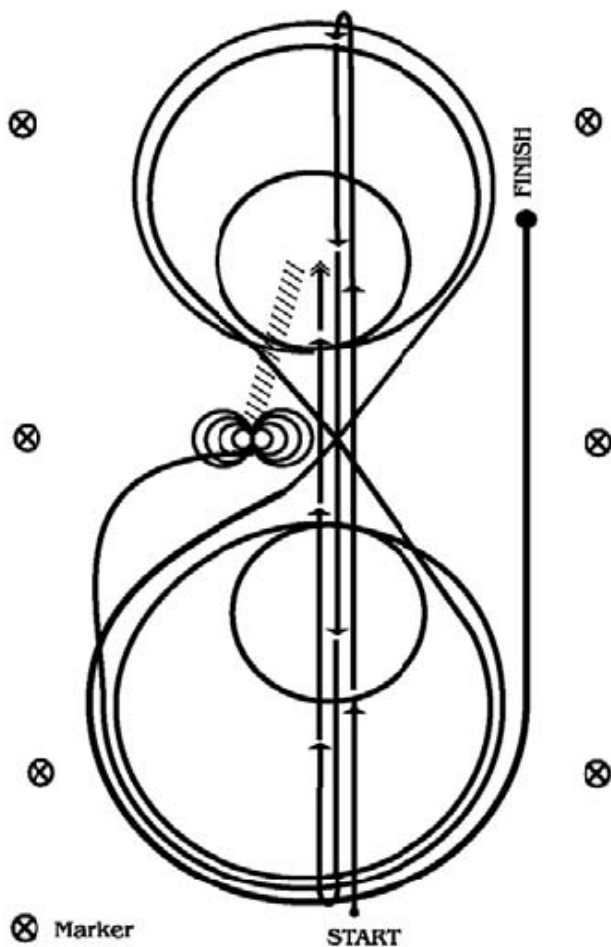

Suitable Reining patterns are available from the Provincial offices and may be requested with application for competition approval.

ARTICLE F1203 NOVICE/ENTRY LEVEL CLASSES

1. Any approved pattern may be used with two spins instead of four.
2. Horses in this class may be shown two handed with a snaffle bit regardless of horse's age.

CHAPTER 13

RANCH RIDING

ARTICLE F1301 GENERAL

The purpose of the ranch riding class is to measure the ability of the horse to be a pleasure to ride while being used as a means of conveyance from performing one ranch task to another. The horse should reflect the versatility, attitude and movement of a working ranch horse riding outside the confines of an arena. The horse should be well-trained, relaxed, quiet, soft and cadenced at all gaits. The ideal ranch horse will travel with forward movement and demonstrate an obvious lengthening of stride at extended gaits. The horse can be ridden with light contact or on a relatively loose rein without requiring undue restraint, but not shown on a full drape of reins. The overall manners and responsiveness of the ranch riding horse to make timely transitions in a smooth and correct manner, as well as the quality of the movement are of primary considerations. The ideal ranch riding horse should have a natural ranch horse appearance from head to tail in each maneuver.

ARTICLE F1302 CLASSES

1. For horses three years of age and older, offered as a junior, senior or all-age open division class.
2. Horses may cross enter western pleasure, walk/trot western pleasure and ranch riding class at the same show regardless of division (youth, amateur, select or open).

ARTICLE F1303 CLASS REQUIREMENTS

1. The required maneuvers will include the walk, trot, and lope both directions: and the extended trot and extended lope at least one direction; as well as stops, and a back.
2. Three optional maneuvers may include a side pass, turns of 360 degrees or more, change of lead (simple or flying), walk, jog, or lope over a pole(s); or some combination of maneuvers that would be reasonable for a ranch horse to perform.
3. The maneuvers may be arranged in various combinations with final approval by the judge.
4. The overall cadence and performance of the gaits should be free-flowing and ground covering for all gaits, with an emphasis on forward movement. Transitions should be performed where designated, with smoothness and responsiveness.
5. No time limit.
6. One of the suggested patterns may be used from the current AQHA Handbook. However, a judge may utilize a different pattern as long as all required maneuvers and the three (or more) optional maneuvers are included. Should a judge use one of his/her own patterns, it is recommended to not have the stop following an extended lope.
7. The use of natural logs is encouraged.
8. Posting at the extended jog is acceptable.
9. Touching or holding the saddle horn is acceptable.

10. Hoof polish is discouraged.
11. It is customary to not remove the hair from the insides of the ears, but horses with clean clipped ears will not be penalized.
12. Trimming of the bridle path, fetlocks or excessive (long) facial hair is allowed.
13. Appointments with silver should not count over a good working outfit. Silver on bridles and saddles and the use of weighted reins is discouraged.
14. When exhibiting in a snaffle bit or hackamore, an exhibitor may switch between two hands and one hand on the reins at any time.

ARTICLE F1304 SCORING

Each horse will work individually, performing the required gait maneuvers and a minimum of three optional maneuvers. Horses will be scored on the basis of 0 to 100, with 70 denoting an average performance. Each maneuver will receive a score that should be added or subtracted from 70 and is subject to a penalty that should be subtracted. Each maneuver will be scored on the following basis, ranging from plus 1 1/2 to minus 1 1/2:

-1 1/2 extremely poor

-1 very poor

-1/2 poor

0 correct

+1/2 good

+ 1 very good

+ 1 1/2 excellent

Maneuver scores are to be determined and assessed independently of penalty points.

PENALTIES

A competitor shall be penalized each time the following occur:

ONE POINT

- Too slow (per gait)
- Over-bridled (per maneuver)
- Out of frame (per maneuver)
- Break of gait at walk or trot for 2 strides or less

THREE POINT

- Break of gait at walk or trot for more than 2 strides
- Break of gait at lope
- Wrong lead or out of lead
- Draped reins (per maneuver)
- Out of lead or cross-cantering more than two strides when changing leads
- Trotting more than three strides when making a simple lead change
- Severe disturbance of any obstacle

FIVE POINT

- Blatant disobedience (kick, bite, buck, rear, etc.) for each refusal

OFF PATTERN

Placed below horses completing all maneuvers

- Eliminates or adds maneuvers
- Incomplete maneuver

ZERO SCORE

- Willful abuse
- Major disobedience or schooling
- Illegal Equipment
- Third refusal or repeated disobedience

No specific penalties will be incurred for nicks/hits on logs but deduction may be made in maneuver score.

No specific penalties will be incurred for over/ under spins but deduction may be made in maneuver score.

RANCH RIDING – PATTERN I

1. Walk
2. Trot
3. Extend the trot, at the top of the arena, stop
4. 360 degree turn to the left
5. Left lead 1/2 circle, lope to the center
6. Change leads (simple or flying)
7. Right lead 1/2 circle
8. Extended lope up the long side of the arena (right lead)
9. Collect back to a lope around the top of the arena and back to center
10. Break down to an extended trot
11. Walk over logs
12. Stop and back

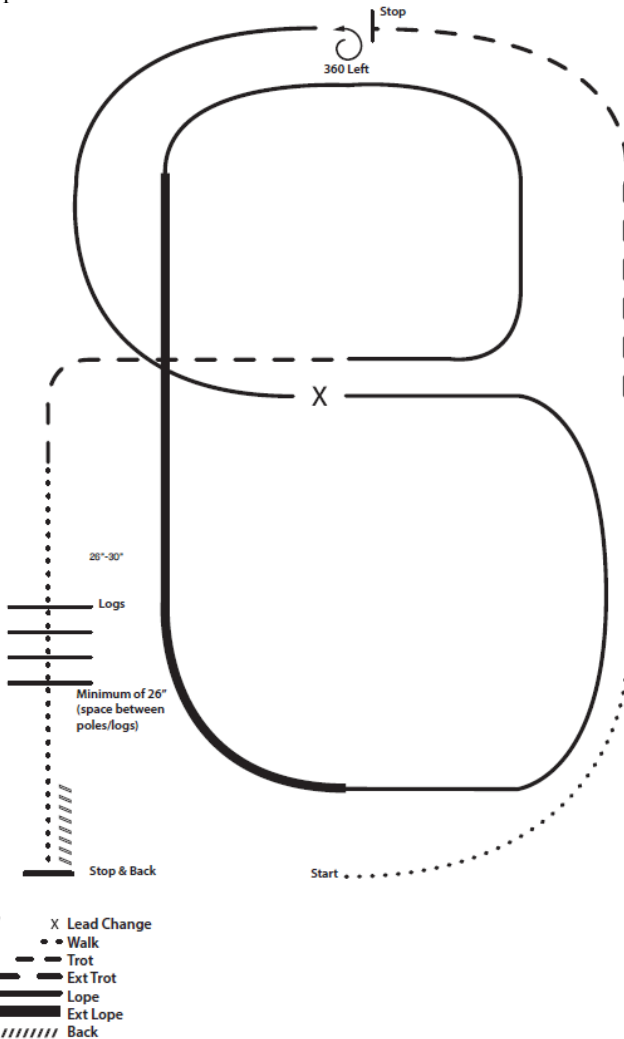

RANCH RIDING – PATTERN II

- a. Walk
- b. Trot
- c. Extended trot
- d. Left lead lope
- e. Stop, 1 1/2 turn right
- f. Extended lope
- g. Collect to working lope-right lead
- h. Change leads (simple or flying)
- i. Walk
- j. Walk over logs
- k. Trot
- l. Extended trot
- m. Stop and back

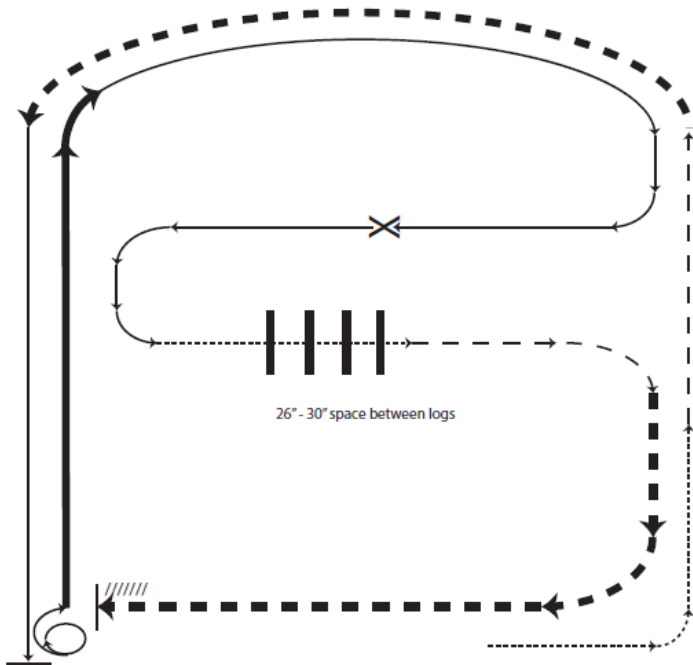

- X Lead Change
- Walk
- - - Trot
- - - Ext Trot
- — — Lope
- — — Ext Lope
- //// //// Back

CHAPTER 14 RANCH TRAIL

ARTICLE F1401 GENERAL

1. The ranch trail class should test the horse's ability to cope with situations encountered while being ridden through a pattern of obstacles generally found during the course of everyday ranch work. The horse/rider team is judged on the correctness, efficiency and pattern accuracy with which the obstacles are negotiated and the attitude and mannerisms exhibited by the horse.
2. Judging emphasis is on identifying the well-broke, responsive and well-mannered horse which can correctly navigate and negotiate the course. The ideal ranch trail horse should have a natural ranch horse appearance from head to tail in each maneuver.
3. At show management option the competition trail course may be made available to exhibitors or posted prior to the day of competition. It must be posted at least one hour prior to competition.

ARTICLE F1402 CLASSES

1. For horses three years of age and older, offered as a junior, senior, or all-age open division class.
2. Horses may cross enter trail horse and ranch trail class at the same show regardless of division (youth, amateur, select, or open).

ARTICLE F1403 CONDUCT

1. The ranch trail course will include no fewer than six and no more than nine obstacles. It is mandatory that the horse be asked to walk, trot and lope during the course. Walk will be evaluated as part of the obstacle score. Trot must be at least 35 feet and scored with the obstacle. Lope must be lead-specific, at least 50 feet and scored with the obstacle. Care must be exercised to avoid setting up any obstacles that may be hazardous to the horse or rider.
2. When setting courses, management will be mindful that the idea is not to trap a horse or eliminate an exhibitor by making an obstacle too difficult. All courses and obstacles are to be constructed with safety in mind so as to reduce the risk for accidents. Show committee shall have the option of setting up the trail course to best fit the conditions. An outdoor course is recommended if appropriate terrain is available. Each single-performance event can be time-consuming, especially with large classes, so it is imperative that time restrictions are placed on this class. The show committee shall select a course that has a continuous and positive flow that can be negotiated in four minutes or less.
3. Judges must inspect the course and have the right and duty to alter the course if it is not in keeping with the intent of the class. Judges may remove or change any obstacles they deem unsafe, nonnegotiable or unnecessarily difficult. Any time a trail obstacle becomes unsafe during a class, it shall be repaired or removed from the course. If the course cannot be repaired and some horses have completed the course, the score for that obstacle shall be deducted from all previous draws in that class.

ARTICLE F1404 COURSES

The course must be designed using the mandatory obstacles and maneuvers plus optional obstacles. Combining two or more of the obstacles is acceptable.
Shw561.6

1. PROHIBITED OBSTACLES:

Tarps, water obstacles with slick bottoms, PVC pipe used as a jump or walk over, tires, rocking or moving bridges, painted logs or poles, logs elevated in a manner that permits such to roll in a dangerous manner, any type of pinwheel regardless of spacing or gait.

2. MANDATORY OBSTACLES AND MANEUVERS

1. Ride over obstacles on the ground (natural logs are required). Walk, trot or lope may be used but only one gait is required.
 - a. Walk-overs: Walk over no more than four logs no more than 10 inches high. The spacing between successive logs should be 26 – 30 inches. The formation may be straight, curved, zigzagged or raised.
 - b. Trot-overs: Trot over no more than four logs no more than 10 inches high. The spacing between successive logs should be 36-42 inches. The formation can be straight, curved, zigzagged or raised.
 - c. Lope-overs: Lope over no more than three logs no more than 10 inches high. No more than two logs may be used in succession. The spacing between logs should be at least 6 to 7 feet. The formation can be straight, curved, zigzagged or raised.
2. Opening, passing through and closing a hinged swinging gate (not a rope gate): Use gate that will not endanger horse or rider and requires minimum side-passing.
3. Ride over wooden bridge: Bridge should be sturdy, safe and negotiated at a walk only. Heavy plywood lying flat on the ground is an acceptable simulation of a bridge. Suggested minimum width shall be 36 inches wide and at least 6 feet long.
4. Backing obstacles: Backing obstacles are to be spaced at a minimum of 28 inches. If elevated, 30 inch spacing is required. Back through and around at least three markers. Back through L, V, U or straight or similarly shaped course which may be elevated no more than 24 inches.
5. Side-pass obstacle: Any object which is safe and of any length may be used to demonstrate responsiveness of the horse to leg signals. Raised side pass obstacles should not exceed 12 inches.
6. Drag an object: For open, cowboy amateur, and limited amateur classes ONLY. The drag is not to be used in youth and rookie classes. Drag may be a complete figure eight and may begin in either direction. The exhibitor must have the rope dallyed on the saddle horn (half or full dally) for the duration of the drag.

3. OPTIONAL OBSTACLES.

Optional obstacles may be used provided the obstacles can be found in everyday ranch work. Optional obstacles from which selections can be made include, but are not limited to:

- A jump obstacle whose center height is not less than 14 inches high or more than 25 inches high. Holding the saddle horn is permissible for this obstacle.
- Only live or stuffed animals which would normally be encountered in an outdoor setting may be used but not to be used in an attempt to spook a horse.
- Carry object from one part of the arena to another.
- Remove and replace materials from a mailbox.
- Trot through cones spaced a minimum of 6 feet apart.
- Cross natural ditches or ride up embankments.

- Swing rope or throw rope at a dummy steer head.
- Step in and out of obstacle.
- Put on slicker or coat.
- Stand to mount with mounting block.
- Walk through water obstacle.
- Open gate on foot.
- Pick up feet.
- Walk through brush.
- Ground tie. (Hobbles are allowed)
- Lead at the trot.

ARTICLE 1405 SCORING

1. All runs begin upon entering the pen and any infractions are subject to penalty at that time (such as two hands on the reins, using either hand to instill fear). The rider has the option of eliminating any obstacle, however this will result in being “off pattern” (OP) and the horse/rider team may not place above others who have completed the pattern correctly. A judge may ask a horse to pass on an obstacle after three refusals or at any time for safety concerns.
2. Credit is given to horse/rider teams who negotiate the obstacles correctly and efficiently. Horses should receive credit for showing attentiveness to obstacles and ability to negotiate through the course when the obstacles warrant it while willingly responding to rider’s cues on more difficult obstacles. Quality of movement and cadence should be considered part of the maneuver score for the obstacle.
3. Natural ranch horse appearance will also be evaluated ranging from plus 1 ½ to minus 1 ½. Maneuver evaluations and penalty applications are to be determined independently.

The following penalties will be applied to each occurrence and be deducted from the final score:

1 POINT

- over-bridled (per maneuver)
- out of frame (per maneuver)
- each hit, bite or stepping on a log, cone plant or any component of the obstacle
- incorrect or break of gait at walk or trot for two (2) strides or less
- both front or hind feet in a single-stride slot or space at a walk or trot
- skipping over or failing to step into required space
- split pole in lope-over
- incorrect number of strides, if specified
- one to two steps on mount/dismount or ground tie except shifting to balance
- wrong lead or out of lead for two (2) strides or less

3 POINTS

- wrong lead or out of lead for more than two (s) strides
- draped reins
- break of gait at lope, except when correcting an incorrect lead
- break of gait at walk or trot for more than two (2) strides
- three to four steps on mount/dismount on ground tie
- trotting for more than three (3) strides in lope departures or when exiting a rollback

- knocking down or over, or severely disturbing an obstacle
- stepping out of or falling off an obstacle with one foot
- missing or evading part of a log/obstacle with one foot

5 POINTS

- spurring in front of cinch
- blatant disobedience
- use of either hand to instill fear
- stepping out of or falling off an obstacle with more than one foot
- dropping an object required to be carried
- 1st or 2nd cumulative refusal
- letting go of gate
- five or more steps on mount/dismount or ground tie
- missing or evading part of a log/obstacle with more than one foot

OFF-PATTERN

- Exhibitors cannot place above others who complete pattern correctly.
- incomplete maneuver
- eliminating or adding a maneuver
- 3rd refusal
- repeated blatant disobedience, and failure to dally and remain dallied during the drag
- use of two hands (except in snaffle bit or hackamore classes designated for two hands), more than one finger between split reins or any fingers between romal reins (except in the two-rein)
- failure to open and shut gate, or failure to complete gate

DISQUALIFIED 0 – SCORE

- lameness
- abuse
- illegal equipment
- disrespect or misconduct
- leaving arena before pattern is complete
- improper western attire
- fall of horse/rider
- out of control, dangerous, or excessive schooling

CHAPTER 15

WORKING WESTERN RAIL

ARTICLE F1501 GENERAL

The working western rail class measures the ability of the horse to be a pleasure to ride and should reflect the versatility, attitude, and movement of a working horse. The horse should be well-broke, relaxed, quiet, soft and cadenced at all gaits. The movement of the working western rail horse should simulate a horse needing to cover long distances, softly and quietly. The overall manners and responsiveness of the horse and the horse's quality of movement are the primary considerations. Maximum credit should be given to the horse that has a natural flowing stride and consistent, ground covering gaits. Transitions should be performed when requested, with smoothness and responsiveness. The ideal working western rail horse should have a natural head carriage at each gait. The horse should be ridden on a relatively loose rein with light contact and without requiring undue restraint while being responsive to the rider and making timely transitions in a smooth and correct manner.

ARTICLE F1502 CLASSES

1. For horses three years of age and older, offered as a junior, senior, or all-age open division class.
2. Horses may cross enter western pleasure, walk/trot western pleasure, and working western rail class at the same show regardless of division (youth, amateur, select, or open).

ARTICLE F1503 CLASS REQUIREMENTS

1. All exhibitors will work as a group. Individuals working off the rail will not be penalized and passing is permissible.
2. Horses must work both ways of the ring at the walk, trot, and lope. Horses must work at least one way of the ring at the extended trot and extended lope. At the option of the judge, horses may be asked to extend their stride at the walk.
3. The overall cadence and performance of the gaits should be as described in the General section, with an emphasis on forward, free-flowing, and ground-covering movement.
4. At the extended trot and lope, the exhibitor may post or stand in the stirrups.
5. Touching or holding the saddle horn during any extended gait is acceptable.
6. Horses are to be reversed to the inside (away from the rail). They may be required to reverse at the walk or trot at the discretion of the judge but shall not be asked to reverse at the lope.
7. Horses are required to back easily and stand quietly. Horses may be brought to the center or backed on the rail.
8. The rider shall not be required to dismount except in the event the judge wishes to check equipment.

ARTICLE 1504 SCORING

Faults scored according to severity:

- Too slow (any gait)
- Excessive speed (any gait)
- Over-bridled (nose behind the vertical)
- Head carried too low such that the poll is below the withers
- Out of frame

- Head carried too high
- Break of gait
- Wrong lead or out of lead
- Failure to take the appropriate gait when called
- Opening mouth excessively
- Draped reins
- Use of spurs forward of the cinch
- Canted at the lope
- Blatant disobedience (kick, bite, buck, rear, etc.)

Faults which will be cause for disqualification:

- Head carried too low and/or clearly behind the vertical excessively and consistently while the horse is in motion or otherwise showing the appearance of intimidation.

PART FOUR WESTERN TIMED CLASSES

CHAPTER 16 WESTERN SPEED EVENTS

ARTICLE F1601 GENERAL

1. No horse/rider combination may compete in a restricted entry class, such as Junior (horse), Amateur, Youth, Men's, Ladies', etc., prior to the Open class of the same event, on the same day, unless there are restricted entry classes for all categories of riders prior to the Open class, or a practice session is also available prior to the event. If a previous class in the same event is also open to all competitors, riders are free to compete in both.
2. Competitors in any individual event should compete in the same arena, on the same day, on the same measured course, and as nearly as possible, under the same conditions.
3. The order of competition shall be determined by drawing lots, or by computerized random sorting.
4. Each competitor shall be ready when called, or may be eliminated at the Judge's discretion.
5. If there is an elimination heat or heats, each horse must be ridden in the main go-round by the same rider who rode it in the elimination. Substitution of horses between heats is not permitted.
6. Ties will not be broken, except to determine class and Championship winners. Money will be split equally between tying entries. A coin will be flipped to determine allocation of ribbons or other awards.
7. In the event of a tie that must be run off, the competitor declared the winner of a run-off must re-run the pattern within two (2) seconds of his/her original time or the run-off must be restaged.
8. Competitors must wait for direction from the ring steward, or the green starting light to be activated, before entering the arena or starting to run the pattern. Competitors must make sure that they understand and obey all starting signals designated by the organizing officials.
9. Where points accumulation is a factor, they will accrue to horse/rider combinations only.
10. The Judge, at his discretion, may eliminate a competitor for excessive use of a bat, crop, whip or **rope in front of the cinch**.

ARTICLE F1602 COURSES

1. Courses. A Competition Manager should keep in mind that a properly prepared speed event horse will negotiate prescribed patterns correctly, at speed. Therefore, no element of a pattern should be adjacent to a fence or wall, if avoidable, as this will "hold in" a horse that is incompletely trained. Each course should be measured, element-to-element, and from the starting line. Fences or walls should not be used as the starting point for measuring the course, unless the arena is too small for the standard pattern.
2. Timing Line.
 - a) Poles indicating the timing line, event officials and equipment are not part of the course and should be as unobtrusive as possible. Where practical, they should be outside of the arena enclosure. Otherwise, timing

- equipment, officials and start/finish line markers should be as close to the sides of the arena enclosure as is feasible.
- b) Barrels should not be used to mark the timing line, or to support the timing equipment.
3. Ground Conditions.
 - a) Speed events are races. Each competitor is attempting to negotiate the course as quickly as possible. Therefore, the arena surface should afford secure footing, at speed. If the surface is hard and/or slippery, it should be worked deeply enough to provide good footing. Any rocks, glass, sticks or other debris that might impair safety or injure the horses should be removed.
 - b) Periodic arena grooming (rakes or drag) should be provided, when the surface is subject to excessive pitting, to give the same footing to each horse. Sufficient stopping distance should be provided beyond the finish line. See the individual event diagrams for recommended stopping distances.
 4. Entry/Exit.
 - a) Competitors must begin and end their run from inside the arena with a closed gate. Running starts, i.e. rodeo starts, are not permitted.
 - b) Adequate space must remain between barrels and any obstacle. Refer to the individual event diagrams for recommended measurements.

ARTICLE F1603 ATTIRE

1. As speed events are Western events and spectator sports, appropriate, tidy Western dress shall be used at all times. This includes, Western Hat, long sleeved Western shirt, and Western riding boots. Non-Western or untidy dress may cause elimination, at the Judge's discretion. Boots/shoes worn while riding anywhere on the competition grounds must have a distinguishable heel.
2. In any speed event class competitors are encouraged to replace the Western hat with approved protective headgear, which is strongly recommended for safety. Junior riders must wear properly fitted, approved protective headgear in the practice area and competition arena.
3. Deliberate discarding of the hat by the competitor, anywhere in the arena, may incur elimination, at the Judge's discretion.
4. Bats, crops, scat bats, spurs, over-&unders, nose and eyebrow tie-downs and mechanical hackamores are to be permitted. However, excessive spurring or cropping may bring elimination at the Judge's discretion. Use of any other equipment that the Judge considers too severe or striking the horse around the head, will result in immediate elimination for that run.

ARTICLE F1604 EQUIPMENT

Western tack, except for bits, must be used. Bits are the option of the competitor, but must be mounted in a Western style headstall. Properly fitted tie downs, martingales and draw reins are optional, but a halter must not be used in place of a proper noseband.

ARTICLE F1605 TIMING

1. An electronic timer, calibrated to thousandths of a second, with a similar, independently reading back-up timer, shall be the preferred method of timing. If the primary timer should fail, all times must then be taken from the back-up timer. All times in any class must always be taken from the same instrument.
2. If an electronic timer is not available, at least two stopwatches must be used, with the average time of the watches to be the official time. Hand held stopwatches are considered to be relatively inaccurate timing instruments, and should be used only as a last resort.
3. A single electronic timer, calibrated to at least hundredths of a second, shall be considered the minimum acceptable timing method for Regional, Provincial, Territorial, National or International Championship classes.
4. Should the timing equipment fail when a competitor has a "clean" run, or incurred time faults which would not eliminate him/her, that competitor will be permitted a maximum of two re-runs to set a time. If he/she runs a correct pattern during the first re-run, he/she will not be allowed a second re-run.
5. Should the timing equipment fail when a reason exists to eliminate the competitor being timed (off course, etc.), he/she will not be allowed another run.
6. If the electronic timing equipment should have a major failure, requiring that the entire class must be re-run, only those competitors that had "clean" runs will be allowed to run again.
7. If an element of the pattern should fall down after the competitor completes his/her course (the timer has stopped), the pattern shall be judged as correct.
8. Running over or striking the timing equipment, starting line markers or running into (correctly positioned) arena personnel while competing shall be cause for elimination.

ARTICLE F1606 BARREL RACING

Barrel racing is a timed event.

1. The course must be measured exactly according to diagram and cannot exceed these dimensions. However, if the course is too large for the available space, the pattern should be reduced 15 feet at a time until the pattern fits the arena. Adequate space must remain between barrels and any obstacle. The distance from barrel number three to the finish line need not be reduced 15 feet at a time if there is sufficient room for the horse to stop. When measuring the area for the barrel course, allow ample room for horses to complete their turns and stop at the finish.
It is recommended there be at least 45 feet (13.5 meters) from the starting line to the end of the arena, at least 18 feet (5.4 meters) from barrels 1 and 2 to the fence and 36 feet (10.8 meters) from barrel 3 to the end of the arena.
2. Brightly colored 55 gallon (200 liters) steel drums with both ends in must be used. Rusty or damaged barrels that might provide a hazard for horses or riders must not be used. No padding, or a tire, which might change the diameter, height or balance of the barrels, may be used. There shall be no rubber or plastic barrels used.
3. Starting line markers or electric timers, when possible, shall be placed against the arena fence. An electric timer or at least two watches shall be used, with the time indicated by the electric timer or average time of the watches used by official timers to be the official time.
4. Timing shall begin as soon as the horse's nose reaches the starting line and will be stopped when the horse's nose passes over the finish line.

5. The competitor is allowed a running start. At a signal from the starter, the competitor will run to barrel number 1, pass to the left of it, and complete an approximately 360 degree turn around it; then go to barrel number 2, pass to the right of it, and complete a slightly more than 360 degree turn around it; then go to barrel number 3, pass to the right of it, and do another approximately 360 degree turn around it; then sprint to the finish line, passing between barrel number 1 and 2. This barrel course may also be run to the left. For example, the competitors will start to barrel number 2, turning to left around this barrel, then to barrel number 1, turning to the right, then to barrel number 3, turning again to the right, followed by the final sprint to the finish line.
6. Knocking over a barrel carries a five-second penalty. Failure to follow the course shall cause disqualification. A competitor may touch the barrel with his or her hands in barrel racing.
7. A five second penalty will be assessed if the hat or approved protective headgear is not on the competitor's head for the entire time the competitor is in the arena in barrel racing.
8. The judge, at his/her discretion, may disqualify a competitor for excessive use of a bat, crop, whip or rope in front of the cinch.
9. If a tie occurs where points are involved, placing will be worked off if all tied competitors agree to participate in a run-off, if not, a coin toss will be used to separate the ties.

BARREL RACING PATTERN

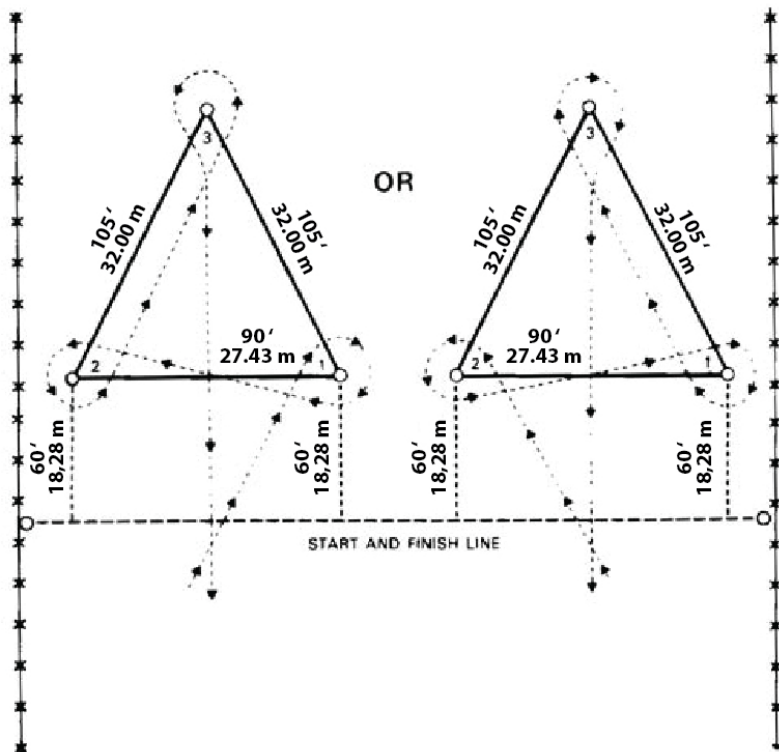

ARTICLE F1607 POLE BENDING

Pole bending is a timed event

1. The official Pole Bending course is indicated in the diagram below. Each competitor will begin from a running start, and time shall begin and end as the horse's nose crosses the line. A clearly visible starting line must be provided. An electric timer or at least two watches shall be used, with the time indicated by the electric timer or the average time of the watches used by official timers to be the official time.
2. The pole bending pattern is to be run around six poles. Each pole is to be 21 feet (6.4 meters) apart, and the first pole is to be 21 feet (6.4 meters) from the starting line. Poles shall be set on top of the ground, six feet (1.8 meters) in height, with no base more than 14 inches (35 cm) in diameter.
3. A horse may start either to the right or to the left of the first pole and then run the remainder of the pattern accordingly.
4. Knocking over a pole shall carry a five-second penalty. Failure to follow the course shall cause disqualification. A competitor may touch a pole with his or her hand in pole bending. If the original course is altered by a rider intentionally grasping a pole, a five second penalty for each pole grasped will be assessed.
5. A five-second penalty will be assessed if the hat or approved protective headgear is not on the competitor's person for the entire time the competitor is in the arena in pole bending.
6. If a tie occurs where points are involved, placing will be worked off if all tied competitors agree to participate in a run-off, if not, a coin toss will be used to separate the ties. The horse declared the winner in the runoff must rerun the pattern within two seconds of its original time or the runoff must be held again. Penalty time will not apply to the two-second rule, but will apply to the final runoff time.
7. The judge, at his/her discretion, may disqualify a competitor for excessive use of a bat, crop, whip or rope in front of the cinch

POLE BENDING PATTERN

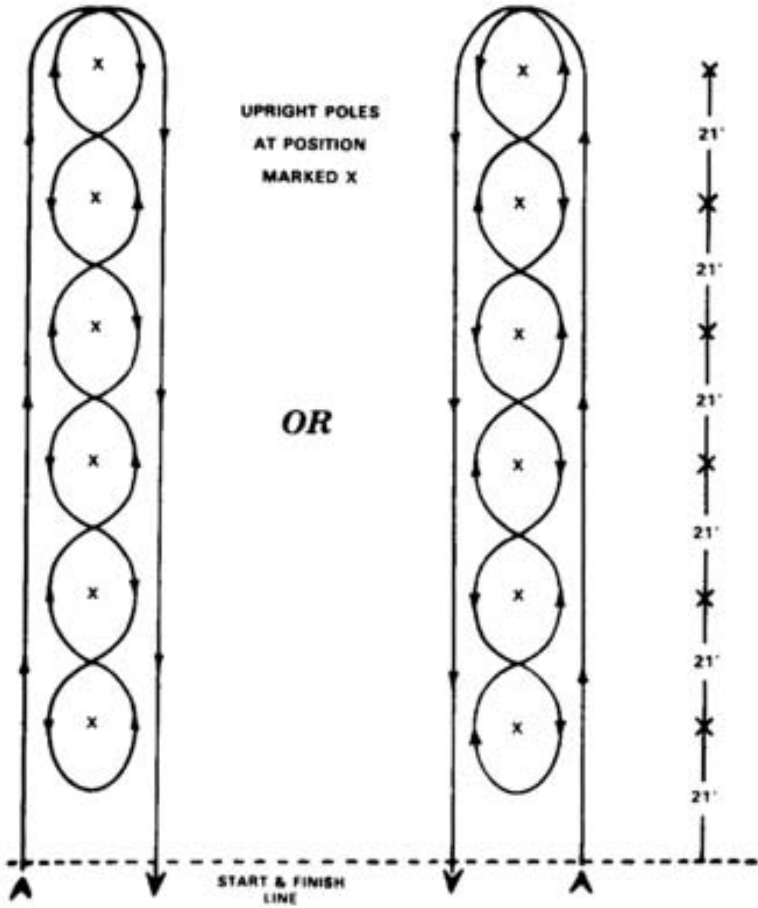

ARTICLE F1608 FLAG RACE

1. The official obstacles of the Flag Race shall be a 45 gallon (200 litre) barrel with both ends closed, and a similar barrel with the top end open. Rusty or damaged barrels that might provide a hazard for horses or riders must not be used.
2. The "flag" shall be a round dowel or pole, 50 - 60 inches (1.27 – 1.5m) long, with no splinters or sharp edges. A commercially available broom handle makes an excellent "flag". The top 15.24 – 30.48cm (6" - 12") may be taped to provide better grip, if wished. Take care to put about 7.5cm (3") of sand (footing) in the bottom of the first barrel.
3. Suggested measurements for the Flag Race pattern are indicated in the diagram below. However, the important thing to ensure is that the course is exactly the same for all competitors.
4. The open-end barrel shall be set on the centre line of the arena, approximately 50 feet (15.24 m) past the timing line. The flagstick shall be placed in this barrel, leaning against the top edge to the right or left, at the competitor's direction. The other barrel shall be placed on the centre line of the arena a further 75 feet (22.86 m) down the arena from the first barrel.
5. The correct pattern shall be: to run across the timing line to the first barrel, passing either to the right or left of it, picking up the flag stick, run to the second barrel, turning around it either to the left or right, then sprint to the timing line, returning the flag stick to the open ended barrel while passing. The competitor may follow a figure-8 pattern, or not, at his/her discretion. The flag can be placed on the left, right or center of the barrel at the discretion of the competitor.
6. Failure to follow the course, knocking over a barrel, failing to return the flagstick to the open barrel, hitting the horse with the flag, or dropping the flag, shall cause a competitor to be eliminated.
7. If the flag breaks, the competitor has the right to two (2) reruns. If the first rerun is without fault there is no right to a second rerun.

FLAG RACE PATTERN

'Reverse ride'
begins from
this end

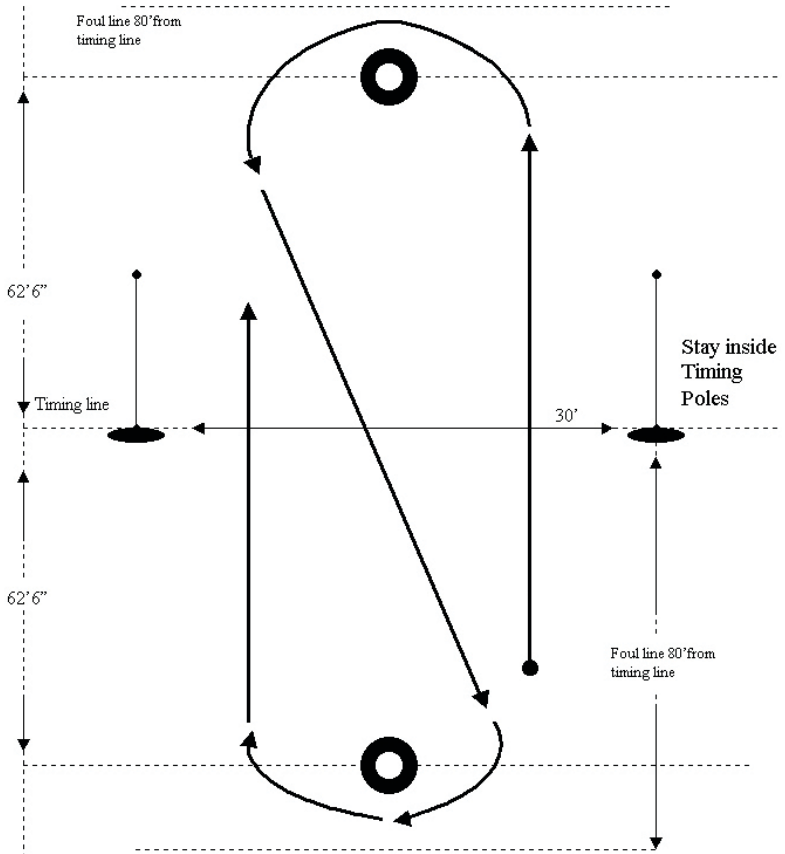

ARTICLE F1609 STAKE RACE

This is a timed event.

1. Timing shall begin as soon as the horse's nose reaches the starting line and will be stopped when the horse's nose passes over the finish line.
2. The competitor is allowed a running start and may begin his run from either the left or right side of the first pole. Start by crossing the center line between the upright markers, turn around the second pole, cross over the center line again between the markers, then around the first pole and run back across the finish line.
3. The start and finish line is 20 feet (6 meters) wide and marked by two upright markers 10 feet (3 meters) on each side of the center line and short enough so as to not interfere with the timer if one is used. Short pylons or cones are recommended. The first and second poles marking the center line are each 40 feet (12 meters) from the start and finish line, making them a total of 80 feet (24 meters) apart.
4. A five-second penalty will be assessed if the hat or approved protective headgear is not on the competitor's person for the entire time the competitor is in the arena in stake racing.
5. Failure of a competitor to cross the start and finish line between the markers shall result in no time.
6. Failure of competitor to cross over the center line between the markers before turning the second pole and cross back over the center line after turning the second pole, shall result in no time.
7. If an upright marker or pole is knocked down, it shall result in no time. If the original course is altered by a rider intentionally grasping a pole, a five-second penalty for each pole grasped will be assessed.
8. All horses must start from same end of arena.
9. If a tie occurs where points are involved, placing will be worked off if all tied competitors agree to participate in a run-off, if not, a coin toss will be used to separate the ties.

STAKE RACE PATTERN

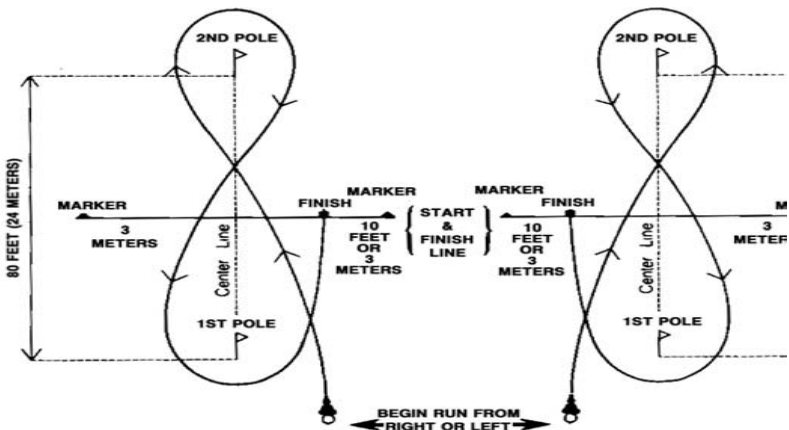

ARTICLE F1610 KEYHOLE RACE

1. The official Keyhole Race Pattern is indicated in the diagram below.
2. The starting line can be from 50 to 100 feet (15.24 – 30.48 m) from the entrance to the circle.
3. The rider must turn the horse around in the circle. The rider is not permitted to walk the horse into or out of the circle. The horse is not permitted to touch or cross over the line when completing the keyhole. Failure to follow course or to step in or out of the circle line will result in elimination.
4. The horse that completes the prescribed course correctly in the fastest time wins.

KEYHOLE RACE PATTERN

Keyhole

Disqualification if horses hoof touches the ground on (or outside) any portion of the keyhole (circle or wings).

Course Pattern: Go through timing poles, run into the circle of the keyhole, turn in either direction, and return through the timing poles. All four of the horses feet must enter the circle.

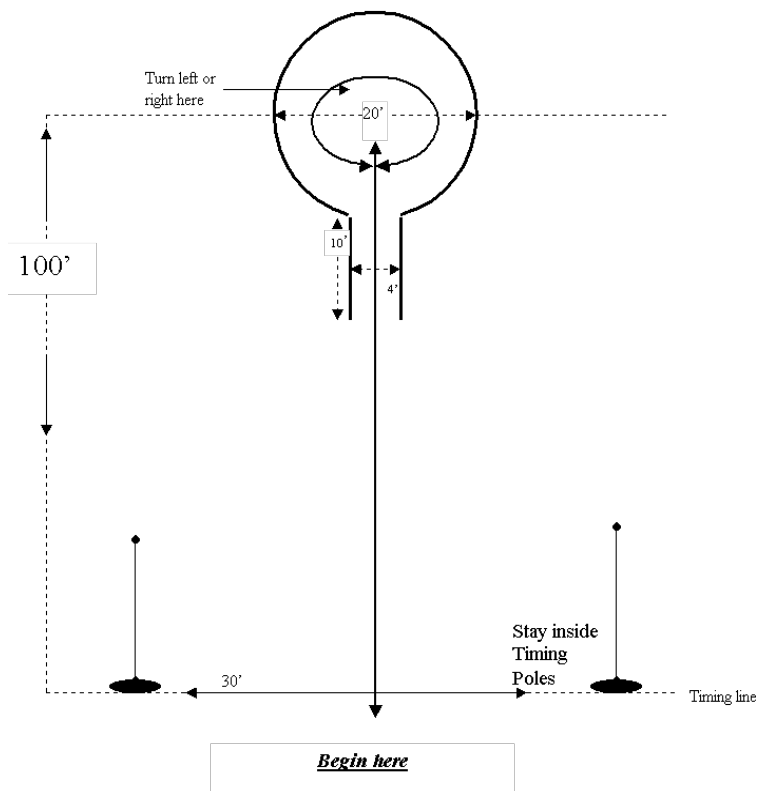

ARTICLE F1611 DASH FOR CASH

1. One barrel is set up 125 feet (38.1 m) from the timing line on the centre line of the arena. Each competitor runs to and around that barrel and back across the timing line.
2. Knocking over a barrel shall cause a competitor to be eliminated.

PART FIVE ENGLISH PERFORMANCE CLASSES

CHAPTER 17 GENERAL PERFORMANCE HUNTER

Heritage Hunter or General Performance classes are run according to the height classification of the division. The hunter division may consist of over fence classes (2 or 3) and optional hunter hack classes

ARTICLE F17401 HUNTER DIVISION FENCE HEIGHT LEVELS

- 2'3" Hunter (0.70m)
- 2' 6" Hunter (0.75m)

Pony heights are not to exceed 2'6" (0.75m)

- 2'9" Hunter (0.85m)
- 3' 0" Hunter (0.90m)

ARTICLE F1702 WORKING HUNTER JUDGING REQUIREMENTS

1. All hunters are judged on their jumping style, manners, and way of going.
2. Horses must be serviceably sound in eye, wind and limb. Horses are not required to jog for soundness.
3. A performance starts when a horse enters the ring and ends when it leaves.
4. A hunter should be flowing and rhythmic, and provide a safe, comfortable ride over the fences.
5. A hunter works on a light rein with light contact, and canters at an even pace.
6. The horse must enter and exit the ring at a walk.
7. A circle is allowed upon entry to the ring, or the horse may proceed directly to the first fence.
8. At the discretion of the show committee, the class may be divided due to the size of the entry
9. A second cumulative refusal, runout or bolting on course results in elimination.
10. Competitions must not require judges to keep more than four cards open at the same time.
11. If the competition management allows for back-to-back classes, the first course must be ridden first and the second, second.
12. Judges must penalize unsafe jumping and bad form over fences, whether touched or untouched.

ARTICLE F1703 FAULTS OVER FENCES

1. The following faults are scored according to the judge's opinion and depending on severity or division.
 - a) Rubbing the jump
 - b) Swapping leads in a line or in front of a jump
 - c) Late lead changes
 - d) Completely missing a lead change
 - e) Freshness
 - f) Kicking up or out
 - g) Spooking
 - h) Pinning ears or ringing tail
 - i) Jumping out of form
 - j) Jumping off the centre line of jump

- k) Poor presentation of animal or rider
 - l) Bucking and/or playing
 - m) Adding a stride in a line with a related distance
 - n) Eliminating a stride in a line with a related distance
 - o) Striking off on a wrong lead on the courtesy circle
2. The following are considered major faults and must be penalized.
 - a) Knockdown of any part of an obstacle
 - b) Refusal or stopping while on course
 - c) Dangerous jumping
 - d) Addressing a jump –coming to a stop in front of a jump in order to show the jump to the horse
 - e) Breaking stride or trotting while on course (Exceptions – where posted on course diagram i.e. trot jumps)
 3. Elimination
 - a) Two refusals over the course
 - b) Off course
 - c) Jumping a fence before it is reset
 - d) Bolting from the ring
 - e) Fall of animal and/or rider
 - f) Stopping for loss of shoe or broken equipment

ARTICLE F1704 HUNTER RIDER ATTIRE

All competitors must be properly dressed in the confines of the arena. This includes inspection of the course and at the presentation of prizes. Competitors should be neatly and suitably dressed in coat, shirt and tie, choker or stock, breeches or jodhpurs and boots. Boots/shoes worn while riding anywhere on the competition grounds must have a distinguishable heel. Black or brown smooth leather half chaps are permissible providing they match the boot colour. Only approved headgears of a conservative colour are allowed. Safety vests may be worn without penalty. In extremely hot or inclement weather, riding jackets are optional at the discretion of the Competition Organizing Committee.

ARTICLE F1705 HUNTER TACK – APPOINTMENTS

1. No bandages or boots are allowed.
2. Whips must be no longer than 75 cm and unweighted.
3. Bits must be humane - wire snaffle either single or double permissible, with or without cheeks.
4. Reins entirely leather, rubber reins may be allowed at the discretion of the judge, steward and/or competition committee in the case of inclement weather.
5. Leather bridle may be double, pelham, single (snaffle) or kimberwick. Bitless bridles are not permitted in the hunter ring.
6. Browbands cannot be coloured or jeweled. Hunting breastplates are optional.
7. Cavessons (cannot have a drop noseband below the bit) permissible.
8. Conventional standing and running martingales (with rein stops): optional except in hunter hack and hunter under saddle classes in which they are not permissible.
9. Saddles of English or forward seat type, black or brown in colour.
10. Saddle pads must be white saddle-shaped pads or sheepskins.
11. Girths: of suitable material in good repair (e.g. leather, leather with elastic ends, white web or string, nylon, neoprene). Sheepskin on girths is permissible.

ARTICLE F1706 COMPETITIONS AREA, SCHOOLING AREA, WARM UP AREA, JUMP CUP REQUIREMENTS

1. All hunter, equitation, and hunter hack arenas and all warm-up arenas: FEI approved breakaway track systems (metal or plastic) are mandatory on the back rails of oxers, middle and back rails of triple bars, and all rails over water.
2. A competition holding classes over fences must provide a safe exercise area with a minimum of one oxer and one vertical fence for practice.
3. Flags on fences in the schooling areas should be used. Flags must be used if the schooling ring becomes congested.

ARTICLE F1707 RAPPING

1. It is forbidden to rap a horse at any time on the competition grounds. Confirmation of rapping results in **disqualification** from the competition and the return of all awards and prizes won.

ARTICLE F1708 FIRST AID & EMERGENCY MEDICAL HELP

It is mandatory that all competitions where persons are required to jump over obstacles have on site emergency medical services with a minimum of advanced first aid and basic cardiac life support (BCLS). A crisis response plan should be prepared in advance of the competition by the competition committee.

ARTICLE F1709 HUNTER COURSES

Only courses approved for General Performance competitions may be used unless a recorded or Senior course designer is employed by the competition. Copies of the courses are available from the PTSO or Equestrian Canada office.

General:

- a) The hunter course will consist of 7 to 8 fences.
- b) Typical hunters have a 12' stride.
- c) If a class is offered for pony's, distances cannot be less than 72' (22m) between fences, unless the appropriate pony distances are used. The distances of lines in feet (or metres) must be available for that course diagram.
- d) There will be no combinations in the hunter course.
- e) Starting a course going in the "home" direction (usually towards the in-gate) provides and encourages the horse to move forward. The 'start' – first fence of the course should ride coming toward home and should be a vertical.
- f) Going down lines starting with a vertical fence and finishing over an oxer encourages a more forward ride and is the easiest line to ride. Only verticals can be used as the first fence in a line.
- g) Fences with lots of ground line are easiest to jump, e.g. brush boxes, natural brush (evergreens) or flowers may be used as a ground line.

SAMPLE HUNTER OVER FENCES COURSE

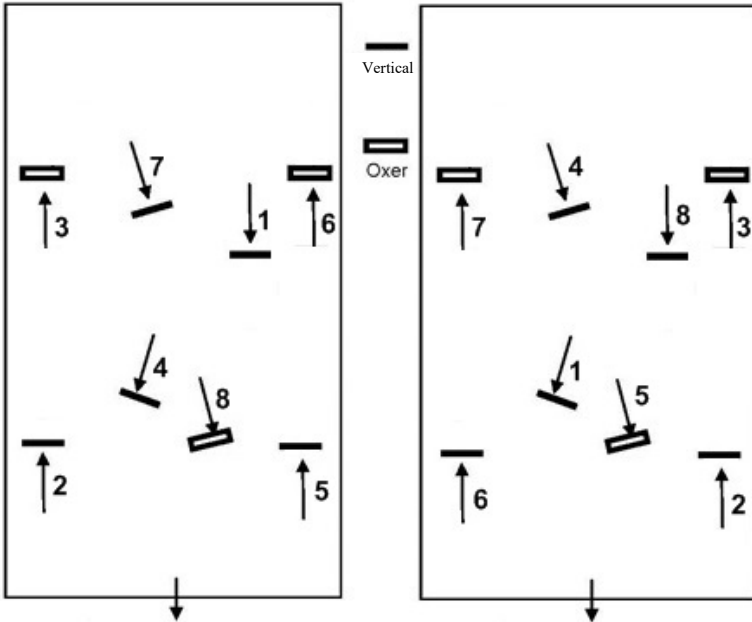

Hunter over fence courses should remain simple allowing the horse to maintain a steady pace around the course. It is recommended that the first fence on course should be a single vertical jumper towards home, which allows the horse and rider to establish an appropriate hunter pace before proceeding down a line of fences. Starting a hunter course with a single oxer or a line is not recommended.

ARTICLE F1710 HORS CONCOURS

No horse or pony will be allowed to show "hors concours" in any hunter classes or divisions. See Article G201.3.

CHAPTER 18

GENERAL PERFORMANCE HUNTER HACK

ARTICLE F1801 HUNTER HACK CLASSES

1. The purpose of hunter hack is to give horses an opportunity to show their expertise over low fences and on the flat. The hunter hack horse should move in the same style as a working hunter. The class will be judged on style over fences, even hunting pace, flat work, manners and way of going. The poll should be level with, or slightly above the withers, to allow proper impulsion behind. The head should not be carried behind the vertical, giving the appearance of intimidation, or be excessively nosed out, giving a resistant appearance.
2. Horses may be asked to jump one or two vertical fences not exceeding 2'6". Oxers should not be used. Hunter Hack fences should not be used as a combination. A ground line is recommended for each jump. The two fences may be either a single line, related distance, or two single fences, with an unrelated distance, i.e. not in a straight line.
3. Horses being considered for an award are then to be shown at a walk, trot and canter both ways of the ring with light contact. Horses may be asked to hand gallop but never more than eight at one time. A judge may run the under saddle portion before the jumping portion.
4. At the discretion of the judge, competitors may be asked to hand gallop, pull up or back and stand quietly following the last fence.
5. Placing for the class shall be determined by allowing a minimum of 70 percent for individual fence work and a maximum of 30 percent for work on the flat.
6. Faults over fences will be scored as in working hunter class. Horses eliminated in over fence portion of the class shall be disqualified.

CHAPTER 19

GENERAL PERFORMANCE JUMPER

ARTICLE F1901 JUMPER DIVISION

1. Heritage Jumper or General Performance classes are run according to the height classification of the division.
2. The jumper division may consist of 2 or 3 classes.
3. A horse rider combination may only enter 2 height levels at a competition.

ARTICLE F1902 JUMPER DIVISION FENCE HEIGHT LEVELS

- 2' 6" Jumper
- 2' 9" Jumper
- 3' 0" Jumper
- 3'3" Jumper

ARTICLE F1903 JUMPER DIVISION GENERAL

1. Safety is of primary importance in a jumper class. All equipment should be in good working order and should be checked prior to its use at the competition.
2. General Performance Jumper divisions are classified according to the maximum height of the fence to be jumped.
3. A jumper competition is a timed event held in an arena where the entry is tested under various conditions while jumping over a course of obstacles.
4. These tests are designed to demonstrate the freedom, energy, skill and obedience of the horse in jumping, and tests the horsemanship skills of the rider.
5. Jumper classes should be simple yet provide enough challenge for both horse and rider to get an idea of the 'feel' of being in the jumper ring.
6. The degree of difficulty of a simple pattern can be changed significantly. How the fence is built, whether a certain fence is a vertical or an oxer, and the distance between fences, are a few of the ways in which to change the degree of difficulty within a simple course plan.
7. In competitions where the jumper classes competition in the hunter ring it is beneficial for all to set courses for the jumpers to allow the use of as much of the existing material as possible, so it does not have to be moved elsewhere.

ARTICLE F1904 JUMPER COURSE DESIGNER

Any General Performance competition that offers Jumper classes must engage the services of a Course Designer with at least a recorded "r" designation.

ARTICLE F1905 JUMPER CLASSES

Jumper classes may be offered as open divisions, or they may be divided according to age categories, with Senior and Junior (that also may be divided into A, B& C).

ARTICLE F1906 JUMPER RIDER ATTIRE

All competitors must be properly dressed in the confines of the arena. This includes inspection of the course and at the presentation of prizes. Competitors should be neatly and suitably dressed in coat, shirt and tie, choker or stock, breeches or jodhpurs and boots. Boots/shoes worn while riding anywhere on the competition grounds must have a distinguishable heel. Black or brown smooth leather half chaps are permissible providing they match the boot colour. Only approved headgears of a conservative

colour are allowed. Safety vests may be worn without penalty. Riders may, at the discretion of the Competition Organizing Committee, be permitted to wear dress or rising shirts with or without chokers and ties or open-necked polo shirts without jackets; no sweatshirts, t-shirts, tank tops or other similar dress will be permitted. Shirts must be neatly tucked into riding breeches.

ARTICLE F1907 COMPETITION AREA, SCHOOLING AREA, WARM UP AREA, JUMP CUP REQUIREMENTS

1. All jumper arenas and all warm up arenas: FEI approved keyhole breakaway track systems (metal or plastic) are mandatory on the back rails of oxers, middle and back rails of triple bars, and all rails over water.
2. For jumper competition and warm up arenas, the maximum depth of the safety cups for the top back pole of a spread obstacle and the top pole of a vertical over water is 18 mm; safety cups used for the centre poles of a triple bar or for lower poles of other obstacles may have a maximum depth of 20 mm.
3. A competition holding classes over fences must provide a safe exercise area with a minimum of one spread and one straight fence for practice.
4. Flags on fences in the schooling areas should be used if there is no steward monitoring the schooling area. Flags must be used if the schooling ring becomes congested.

ARTICLE F1908 RAPPING

It is forbidden to rap a horse at any time on the competition grounds. Confirmation of rapping results in **disqualification** from the competition and the return of all awards and prizes won

ARTICLE F1909 FIRST AID & EMERGENCY MEDICAL HELP

It is mandatory that all competitions where persons are required to jump over obstacles have on site emergency medical services with a minimum of advanced first aid and basic cardiac life support (BCLS). A crisis response plan should be prepared in advance of the competition by the competition committee.

ARTICLE F1910 JUMPER TACK

1. Draw reins must be used in a safe manner. Draw reins are permitted in the schooling area. Draw reins are permitted over fences if used in the following manner:
 - a) attached to the girth, running through the front legs and secured at the neck (see Figure 1),
 - b) attached to the breastplate (see Figure 2),
 - c) attached to the girth at the billet straps, or
 - d) attached to the “D” rings at the front of the saddle.Standing martingales and draw reins secured as above will be permitted in jumper classes where the height of the fences does not exceed 1.15m. Junior, amateur or non-pro riders may not compete in draw rein
2. Restrictive devices such as the German martingale, de Gogue, chambon, running reins etc. may be used for schooling on the flat but are not permissible over fences or in the competition ring.
3. Blinkers are forbidden.
4. Reins must be attached to the bit(s) or directly to the bridle.
5. Sheepskin may be used on each cheek piece of the bridle providing the sheepskin does not exceed 3cm in diameter measured from the horse's face.

6. In the competition arena:
 - a) If running martingales are used, they must be unrestricted (For use of standing martingales, see Section G, Annex 1).
 - b) Gags and hackamores are allowed.
7. Anywhere on the competition grounds:
 - a) In the interests of safety, the stirrup iron and the stirrup leather (this also applies to safety stirrups) must hang freely from the bar of the saddle and the outside of the flap. There must be no other restrictions or attachments of any kind. The competitor must not directly or indirectly tie any part of his body to the saddlery.
 - b) Competitors are allowed to use a dressage whip of 110 cm when working on the flat but are strictly forbidden to use or carry a whip which is weighed down at the end at any time, or to carry or use one which is more than 75 cm in length in the arena, exercise or schooling areas when riding over poles over any obstacles. No substitute for a whip may be carried.
8. Running, Irish, bib, etc. martingales must be used with rein stops where appropriate.
9. Riders may carry unweighted whips not longer than 75 cm (30") when jumping fences.

Proper use of Draw Reins when Attached between the Front Legs

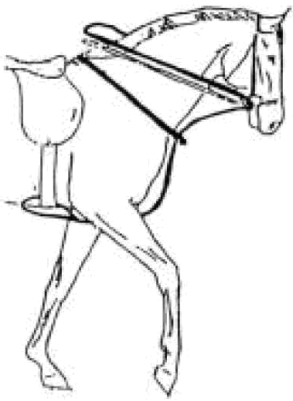

Figure 1. Acceptable- Through neck strap

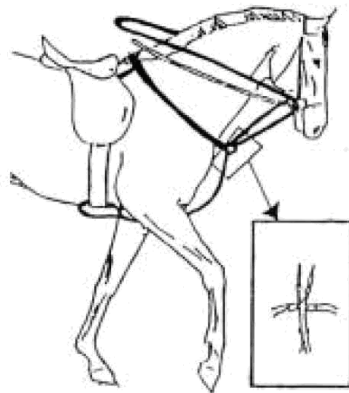

Figure 2. Acceptable- Attached to breastplate.

ARTICLE F1911 JUMPER COURSES, MEASURING

1. The course is the track the competitor must follow when competing from passing the starting flags up to the finishing flags. The length must be measured accurately to the nearest metre, taking account of the normal line to be followed by the horse. This line must pass through the centre of the fence.
2. The total length of the course in metres may never exceed the number of obstacles in the competition multiplied by 60.
3. The starting line may not be more than 25m nor less than 6 m from the first obstacle. The finishing line may not be less than 15m nor more than 25m from the last obstacle. In indoor arenas the finishing line may not be less than 10m from the last obstacle. These two lines must each be marked with an entirely red flag on the right and an entirely white flag on the left.

ARTICLE F1912 CONDUCT OF A JUMPER CLASS

1. A horse is judged solely on performance over a pre-designed jumper course.
2. The course must be posted at least 30 minutes before the start of the class.
3. The 'order-of-go' must be posted at least 30 minutes before the start of the class. Where a rider has more than one horse in the class, the order of go should provide at least five horses between the rider's horses. The other horses will be moved up in order to satisfy this rule.
4. Time Allowed is based on the actual length of the course, should be generous, and must be given for each class.
5. Time limit is equal to twice the time allowed.
6. Time is recorded in seconds and one/hundredths of a second.
7. An obstacle may be one single jump (element), or a series of jumps in a line. 60' is considered a proper minimum distance *between obstacles* in a jumper course, but requires a large ring for this 60' distance.

ARTICLE F1913 SCORING THE JUMPER ROUND

1. Timing is the responsibility of the judge.
2. Electronic timing should be used if possible.
3. Without electronic timing, two timers using stopwatches are preferable, averaging the times for the official time.
4. Late and post entries go first in a class when they are accepted after the order of go is drawn.
5. The judge's whistle signals the start of a round, after which the horse has 45 seconds to cross the starting line. The 45 second countdown sets the time the Athlete can spare before commencing his/her round. The running time for the course is immediately started at the end of the 45 second countdown.
6. Riders are permitted to walk the course,
7. A whistle or bell is used to communicate with the riders to: to start the competition, and to stop the clock during a knockdown or other incidents on course.
8. Flags are used on the jumps to indicate the approach to be taken. Red flags indicate right hand side and white flags the left-hand side of the jumps.

Jump Off:

1. Only competitors who are in equal first place after one or several preliminary rounds of the same competition may take part in a jump off.
2. The order of starting in the jump off must remain the same as the order of starting for the original round.
3. The course may be shortened to a minimum of 6 fences, but do not have to raised or widened.
4. The jump off must be conducted under the same rules and table as the original class.

TABLE A PENALTIES:

First disobedience.....	4 penalties
Obstacle knocked down while jumping.....	4 penalties
First fall of horse or rider or both in class.....	Elimination
Second disobedience or other infringement set forth under Section G Article 241.....	Elimination
Refusal, plus knocking down an obstacle.....	4 penalties + six second time penalty
Exceeding the time allowed in all competitions run under table A.....	1 penalty for each second commenced
Exceeding the time limit.....	Elimination

- Penalties for disobediences accumulate not just at the same obstacle but throughout the entire round.
- The Athlete has the right to jump one single obstacle, after retiring or after being eliminated, providing that obstacle is part of the course of the current competition. This however does not apply to elimination resulting from a fall. See Section G FEI Article 241.
- The whip is not to be used after elimination or after a horse has jumped the last fence on a course. A horse should never be hit more than three times for any one incident. A person identified as misusing or excessively using whip will be disqualified at the discretion of the Ground Jury.

SCORING UNDER TABLE A:

1. Adding together the penalties for faults at the obstacles and the time penalties give the score obtained by the competitor for the round. The courses should be set according to the Optimum time allowed.
2. Time may be used as a deciding factor to separate quality for first place and/or lower places according to the specifications given for the competition.

ARTICLE F1914 HORS CONCOURS

1. "Hors Concours" entries may be accepted at the competition committee's discretion but are subject to the same rules as a regular entry. Hors Concours may not participate in any jump-off.
2. A horse or pony that has competed "Hors Concours" is not permitted to be judged in the same ring on the same day. A horse or pony may only compete "Hors Concours" once in the same ring on the same day. See Article G501.

PART SIX

ENGLISH UNDER SADDLE CLASSES

CHAPTER 20

HUNTER UNDER SADDLE

ARTICLE F2001 HUNTER UNDER SADDLE

1. Hunters under saddle should be suitable to purpose. Hunters should move with long, low strides reaching forward with ease and smoothness, be able to lengthen stride and cover ground with relaxed, free-flowing movement, while exhibiting correct gaits that are of the proper cadence. The quality of the movement and the consistency of the gaits is a major consideration. Horses should be obedient, have a bright expression with alert ears, and should respond willingly to the rider with light leg and hand contact. Horses should be responsive and smooth in transition. When asked to hand gallop, they should move out with the same flowing motion. The poll should be level with, or slightly above, the withers to allow proper impulsion behind. The head position should be slightly in front of, or on, the vertical.
2. This class will be judged on performance, condition and conformation. Maximum credit shall be given to the flowing, balanced, willing horse.
3. Horses to be: shown under saddle, not to jump. Shown at a walk, trot and canter both ways of the ring. Horses may be asked to change to canter from the flat-footed walk or trot, at the judge's discretion.
4. Faults to be scored according to severity:
 - Quick, short or vertical strides
 - Being on the wrong lead at the canter
 - Breaking gait
 - Excessive speed at any gait
 - Excessive slowness in any gait, loss of forward momentum
 - Failure to take the appropriate gait when called for
 - Head carried too high
 - Head carried too low (such that poll is below the withers)
 - Overflexing or straining neck in head carriage so the nose is carried behind the vertical
 - Excessive nosing out
 - Failure to maintain light contact with horse's mouth
 - Stumbling
 - If a horse appears sullen, dull, lethargic, emaciated, drawn or overly tired
5. Faults which will be cause for disqualification, except in novice amateur or novice youth, which shall be faults scored according to severity:
 - Head carried too low (such that poll is below the withers consistently)
 - Overflexing or straining neck in head carriage so the nose is carried behind the vertical consistently
6. At the option of the judge, horses may be required to hand gallop, one or both ways of the ring. Never more than 8 horses to hand gallop at one time. Pre-green and green horses not to hand gallop.

CHAPTER 21

GENERAL PERFORMANCE HACK CLASSES

ARTICLE F2101 HACK DIVISION

1. The hack division has been created to show the versatility of a horse or pony on the flat. The well-rounded hack horse or pony shows the versatility to perform well and adjust his way of going in each of these classes.
2. Horses or ponies in this division may be any breed or combination of breeds, and must have natural action (i.e. not high and/or weighted).

ARTICLE F2102 HACK CLASSES

1. Classes may be held for horses or ponies but combined horse-pony classes are permitted; when classes for ponies are divided by height, such division must be made according to hunter pony heights. See Rules of Equestrian Canada, Section A, General Regulations, Glossary for definition of Pony.)
2. When classes for horses are divided by height into two sections, they shall be:
 - over 14.2 up to and including 15.3 hands
 - over 15.3 hands
3. When classes for horses are divided by height into three sections, they shall be:
 - over 14.2 up to and including 15.2 hands
 - over 15.2 up to and including 16.0 hands
 - over 16.0 hands
4. Classes offered may be grouped according to the rider (i.e. the rider's age) and according to the ribbons won by the horse (i.e. maiden, novice and limit).
5. a) In Stake or Championship classes, horses may be stripped and judged on conformation. It must be stated in the prize list if horses are to be stripped.
b) If stripping is required, after performing collectively, all animals will be stripped and judged for conformation and shown at the walk and trot in hand by the rider. A groom is required for each competitor at this time to assist the rider in stripping the horse. Once conformation judging is finished, riders -do not need to remount before the final placings are announced.

ARTICLE F2103 HACK DIVISION TACK

1. English saddle of any type is required.
2. Bridles may be double, Pelham or snaffle or kimberwick.
3. Martingales, breastplates, boots of any kind and/or bandages are not allowed.
4. Dropped and flash nosebands are prohibited.
5. Browbands shall be leather of any description but not solid white, coloured or sequined.
6. Spurs are optional
7. Whips are NOT permitted in any hack class. See Section A, General Regulations regarding the use of whips in the warm up areas.

ARTICLE F2104 HACK DIVISION ATTIRE

1. Permitted attire: Black jacket or dark coat, approved protective headgear*, white or light tan breeches, jodhpurs, white hunting stock or chokers, black boots. Boots/shoes worn while riding anywhere on the competition grounds must have a distinguishable heel. Tweed jackets are permitted at the option of the organizing committee.
2. Prohibited: saddle suits and/or Kentucky jodhpurs (road hack/show hack only).
3. Spurs are optional.

* See Glossary – *Headgear Standards*.

ARTICLE F2105 HACK DIVISION CHAMPIONSHIPS

1. Points are to be awarded as follows:

Placing	Points
1 st	7
2 nd	5
3 rd	4
4 th	3
5 th	2
6 th	1

2. In the event of a tie, horses shall be shown in hand and judged on conformation.
3. In the event that a competition is offering a Championship in the hack division, it must specify in its prize list those classes which will qualify for the championship.
4. Points accumulated by a horse may not count in more than one hack division. (i.e. if a gentleman's hack is held, points may be credited towards the Championship, but a horse may not be credited with points from both gentleman's and ladies hack).
5. All competitors must have an equal opportunity to earn points towards any Championship that is offered-

ARTICLE F2106 SHOW HACK HORSE OR SHOW HACK PONY

1. **Type and Characteristics:** Show hacks must have vitality, animation, presence, balance and clean fine limbs showing supreme quality. Soundness is required and blemishes may be penalized. Braiding of mane and tail is optional.
2. **Gaits:**
 - a) The walk; straight, four beat and flat-footed, may be required as follows:
 - (i) Normal
 - (ii) Collected
 - (iii) Extended
 - b) The trot: free, light and crisp, may be required as follows:
 - (i) Normal
 - (ii) Collected with rider sitting
 - (iii) Extended - on contact - medium speed with legs moving forward with impulsion and the rider posting or sitting.
 - c) The canter may be required as follows:
 - (i) Collected
 - (ii) Normal
 - (iii) Extended
 - (iv) Hand gallop under control.

3. **Class Routine and Judging:**
 - a) Horses to enter ring at a walk.
 - b) To be shown at a walk, trot, canter and hand gallop; collected and extended gaits to be called for; to stand quietly; only 8 horses to hand gallop at one time.
 - c) To be judged on 55% performance, 20% quality, 15% conformation and 10% manners.

ARTICLE F2107 ROAD HACK HORSE OR ROAD HACK PONY

1. **Type and Characteristics:** The horse and pony must present an appearance of overall substance with refinement. Soundness is required and blemishes may be penalized. Braiding of mane and tail is optional.
2. **Gaits:**
 - a) The walk: straight, four beat and flat-footed with medium contact.
 - b) The trot: straight and true; may be required as follows:
 - normal on light to medium contact
 - strong trot
 - c) The canter: normal on light to medium contact
 - d) Hand gallop under control
3. **Class Routine and Judging:**
 - a) Horses to enter ring at a walk.
 - b) To be shown at a flat-footed walk with a reasonably loose rein, trot, strong trot, easy canter and hand gallop. Only 8 horses to hand gallop at one time.
 - c) To be judged on 55% performance, 20% substance, 15% conformation and 10% manners.

ARTICLE F2108 ENGLISH PLEASURE HORSE OR HACK, ENGLISH PLEASURE PONY OR PONY HACK

1. **Type and Characteristics:** see Article F1801.
2. **Class routine and judging:**
 - a) To be shown at a flat-footed walk, normal trot and easy canter, and to back easily and stand quietly; not to gallop; light contact to be maintained.
 - b) To be judged on 45% performance, 40% manners and 15% conformation.

ARTICLE F2109 OPEN ENGLISH PLEASURE HORSE OR PONY ALL BREEDS NON-RESTRICTED AS TO TACK AND ATTIRE

1. Classes may be divided into Saddle Seat or Hunter Seat.
2. To be shown at a flat-footed walk, normal trot and easy canter, and to back easily and stand quietly; not to gallop; light contact with the horse's mouth; to be judged on manners, performance, quality and conformation.
3. Tack and personal appointments to be appropriate to the seat being ridden.
4. If ridden by a junior, heights of ponies and age of riders to be the same as in pony hunters.

PART SEVEN

GENERAL PERFORMANCE SHOWMANSHIP CLASSES

CHAPTER 22

GENERAL PERFORMANCE SHOWMANSHIP AT HALTER

ARTICLE F2201 GENERAL

1. The showmanship class shall be judged strictly on the competitor's ability to fit and show a horse at halter. The horse is merely a prop to demonstrate the ability and preparation of the competitor. The ideal showmanship performance consists of a poised, confident, neatly attired competitor, leading a well-groomed and conditioned horse that quickly and efficiently performs the requested pattern with promptness, smoothness, and precision. The showmanship class is not a halter class and should not be judged as such.
2. It is mandatory that the judge post any pattern(s) to be worked at least one hour prior to the commencement of the class; however, if the judge requires additional work of competitors for consideration of final placing, the finals pattern may be posted. Pattern(s) should be designed to test the showman's ability to effectively present a horse to the judge. All ties will be broken at the judge's discretion.
3. Showmanship whips (dressage whips etc.), war bridles or like devices or any type of wire or rope over a horse's head are not permitted for showmanship purposes.
4. It is optional to trim the sensory hairs around the eyes and muzzle, hair inside the ears, or feathers on the lower legs.
5. The competitor should use the quarter method when presenting the horse.

ARTICLE F2202 CLASS PROCEDURES

All competitors may enter the ring and then work individually or each competitor may be worked from the gate individually. When competitors are worked individually from the gate, a working order is required. The following maneuvers are considered acceptable: lead the horse at a walk, jog, trot or extended trot, or back in a straight or curved line, or a combination of straight and curved lines, stop; and turn 90 (1/4), 180 (1/2), 270 (3/4), 360 (full turn) degrees or any combination or multiple of these turns. The judge must have competitors set the horse up squarely for inspection during the class.

ARTICLE F2203 SCORING

Exhibitors are to be scored from 0 to infinity, with 70 denoting an average performance. Patterns will be divided into 6 to 10 maneuvers, as specified by the judge, and each maneuver will be scored from +3 to -3 with 1/2 point increments acceptable that will be added or subtracted from 70. Maneuver scores should be determined independent of penalties, and should reflect equal consideration of both performance of the exhibitor's pattern and the form and effectiveness of the exhibitor and presentation of horse to result in the following scores:

- +3 Excellent
- +2 Very Good
- +1 Good
- 0 Average or Correct

- 1 Poor
- 2 Very Poor
- 3 Extremely Poor

Exhibitors overall form and effectiveness should also be scored from 0 to 5 with 0 to 2 Average, 3 Good, 4 Very Good, 5 Excellent.

FAULTS

An exhibitor should be penalized in the pattern independent of maneuver scores and deducted from the final score as follows:

THREE POINTS

- Break of gait at the walk or trot up to 2 strides
- Over or under turning up to 1/8 of a turn
- Ticking or hitting cone
- Sliding a pivot foot
- Lifting a pivot foot during a pivot or set-up and replacing it in the same place
- Lifting a foot in a set-up and replacing it in the same place after presentation

FIVE POINTS

- Not performing the specific gait or not stopping within 10 feet (3 meters) of designated location
- Break of gait at walk or trot for more than 2 strides
- Splitting the cone (cone between the horse and exhibitor)
- Horse stepping out of or moving the hind end significantly during a pivot or turn
- Horse stepping out of set-up after presentation
- Horse resting a foot or hipshot in a set-up
- Over or under turning 1/8 to 1/4 turn

TEN POINTS

- Exhibitor is not in the required position during inspection
- Exhibitor touching the horse or kicking or pointing their feet at the horse's feet during the set-up
- Standing directly in front of the horse
- Loss of lead shank, holding chain or two hands on shank
- Blatant disobedience including kicking, rearing or pawing; horse continually circling exhibitor
- Horse stepping out of or moving the hind end significantly during a pivot or turn more than one time

DISQUALIFICATIONS (cannot place)

- Loss of control of horse that endangers exhibitor, other horses, or judge
- Horse becomes separated from exhibitor
- Failure to display correct number
- Willful abuse Excessive schooling or training; use of artificial aids
- Illegal equipment
- Off pattern, including: knocking over or wrong side of cone or marker; never performing designated gait; over or under turning more than 1/4 turn

ARTICLE F2204 NOVICE/ENTRY LEVEL CLASSES

Exhibitor's going off pattern, knocking over or on wrong side of cone, never performing specified gait, or overturning more than 1/4 turn than designated, shall not be disqualified, but must always place below exhibitors not incurring a disqualifying fault.

PART EIGHT GENERAL PERFORMANCE EQUITATION CLASSES

CHAPTER 23 GENERAL PERFORMANCE EQUITATION RULES

ARTICLE F2301 GENERAL EQUITATION RULES

1. The Equitation division includes two separate sections: Hunter Seat Equitation and Western Horsemanship.
2. The competition prize list and program, if available, must clearly state which section(s) and classes are offered.
3. See also chapters on specific sections of the equitation division.

ARTICLE F2302 DIVISION OF CLASSES

If more than fifty entries in any section of equitation are received by a competition, the competition management must split the class. Some equitation sections require a split with fewer entries. See specific chapters for exceptions.

ARTICLE F2303 AGE OF JUNIOR COMPETITORS

See Rules of Equestrian Canada, Section A, General Regulations, Glossary.

ARTICLE F2304 JUDGING REQUIREMENTS

1. Only the rider is being judged in equitation classes. Any horse that is suitable for a particular riding style and can perform the required routine is acceptable.
2. Any riders not having their mount under sufficient control shall be dismissed from the ring and eliminated from that class.
3. Riders must remain on the same mount throughout all phases of an equitation class.
4. No attendant shall be allowed in the ring except at the request of the judge.

ARTICLE F2305 SOUNDNESS

The judge has the right and duty to excuse a horse that is visibly unsound.

ARTICLE F2306 MAIDEN, NOVICE AND LIMIT

1. In determining the maiden, novice or limit status of riders, first place ribbons won in any section of the equitation division shall be counted in the aggregate; that is, if a rider wins a first in Western Horsemanship, another in hunter seat and a third in saddle seat, that rider has won three first ribbons and is ineligible for further competition in novice classes in the equitation division.
2. In the hunter seat section, ribbons won in classes not to jump shall not affect a rider's status in classes over fences. However, ribbons won in classes over fences shall affect a rider's status in classes not to jump.
3. Ribbons won in lead-line classes and in classes where entries are not required to ride at all gaits will not be counted when reckoning eligibility for maiden, novice and limit classes in any section.

CHAPTER 24

GENERAL PERFORMANCE HUNT SEAT EQUITATION

GENERAL RULES

General Performance Hunter Seat equitation includes flat and over fences classes.

ARTICLE F2401 HUNT SEAT EQUITATION DRESS

1. While competitors and judges should bear in mind that entries are being judged at all times on ability, it should be noted that neatness is a first requisite regarding rider's dress.
2. The following requirements are based on tradition and present day custom.
Jacket – tweed or conservative colour. Ties or chokers may be worn. Spurs of the unrowelled type, whip or crop optional. No whip may exceed 75cm (30") in length. Boots/shoes worn while riding anywhere on the competition grounds must have a distinguishable heel.

ARTICLE F2402 APPROVED PROTECTIVE HEADGEAR

All competitors must wear properly fitted, approved protective headgear with safety harness fastened. See the Glossary – *Headgear Standards*.

ARTICLE F2403 HUNT SEAT TACK

1. Only regular cavessons with snaffles, pelhams, double bridles or kimberwicks are permissible. Pelham converters allowed only in Junior "B" and "C" classes. Reins must be made entirely of leather.
2. Saddle should be plain English or modified jumping. Extreme forward seat is not recommended.
3. Running or standing martingales are not permitted in flat classes. They are optional in over fences classes.
4. Boots and conservative coloured bandages are permitted in hunter seat equitation classes.
5. To facilitate the judge's view of the rider's foot position, black or coloured stirrups or stirrups with black or coloured branches are not permitted, and, if used, will incur elimination. Only silver/grey or silver/grey safety stirrups with elastics of any colour are permitted.

ARTICLE F2404 HUNT SEAT EQUITATION BASIC POSITION

1. The communication between horse and rider through subtle cues and aids should not be obvious. Equitation is judged on the rider and his/her effect on the horse. Hunt seat equitation on the flat provides a base for a natural progression to over fence classes. The poll should be level with, or slightly above the withers, to allow proper impulsion behind. The head should not be carried behind the vertical, giving the appearance of intimidation, or be excessively nosed out, giving a resistant appearance.
2. A turn on the forehand to the right is accomplished by moving haunches to the left. A forehand turn to the left is accomplished by moving haunches to the right. When performing a leg-yield, the horse should move forward and lateral in a diagonal direction with the horse's body straight with a slight flexion of the head in the opposite direction of lateral movement. When a horse yields to the right, the head is slightly (just to see the eye of the horse) to the left. A horse yielding to the left, the head is slightly flexed to the right.

3. Basic Position:
 - a) Hands should be over and in front of horse's withers, knuckles thirty degrees inside the vertical, hands slightly apart and making a straight line from horse's mouth to rider's elbow. Method of holding reins is optional, and bight of reins may fall on either side. However, all reins must be picked up at the same time.
 - b) The eyes should be up and shoulders back. Toes should be at an angle best suited to rider's conformation; heels down, calf of leg in contact with horse. Iron should be on the ball of the foot and must not be tied to the girth.
4. Gaits
 - a) THE WALK: Should be a 4-beat gait with the rider in a vertical position with a following hand.
 - b) THE POSTING TROT: Figure 8 at trot, demonstrating change of diagonals. At left diagonal, rider should be sitting the saddle when left front leg is on the ground; at right diagonal rider should be sitting the saddle when right front leg is on the ground; when circling clockwise at a trot, rider should be on left diagonal; when circling counter-clockwise, rider should be on right diagonal. The rider should close his/her hip angle to allow his/her torso to follow the horizontal motion of the horse. The upper body should be inclined about 20 degrees in front of the vertical.
 - c) SITTING TROT AND CANTER: At the sitting trot the upper body is only slightly in front of the vertical. At the canter the body should be positioned slightly more in front of the vertical. As the stride is shortened, the body should be in a slightly more erect position.
 - d) TWO-POINT POSITION: The pelvis should be forward, but relaxed, lifting the rider's weight off the horse's back and transferring the weight through the rider's legs. In this position the two points of contact between horse and rider are the rider's legs. Hands should be forward, up the neck, not resting on the neck.
 - e) HAND GALLOP: A three-beat, lengthened canter ridden in two-point position. The legs are on the horse's sides while the seat is held out of the saddle. When at the hand gallop, the rider's angulation will vary somewhat as the horse's stride is shortened and lengthened. A good standard at a normal hand gallop should be about 30 degrees in front of the vertical

ARTICLE F2405 HUNT SEAT CLASS ROUTINE ON THE FLAT

1. The Class will proceed at least once around the ring at each gait – walk, trot, sitting trot and canter and on command, reverse and repeat. Individual tests may be used before or after the rail phase.
2. Individual tests used before rail phase must be posted at least one hour prior to the class commencing.
3. When individual tests are desired after the rail phase, the judge's oral instructions to riders shall be publicly announced. It is suggested that the judge review these instructions with the announcer immediately prior to the class to ensure mutual understanding of the wording.
4. Individual work may be comprised of any of the following:
 - walk, trot or canter in a straight line, curve, or circle, or any combination of these gaits and patterns, such as a figure eight, etc.;
 - stop;
 - back;

- simple change of lead through the trot or walk in a straight line, figure eight or any other pattern; and/or
- flying change of lead in a straight line, figure eight, or any other pattern.

Markers help to standardize patterns and guides riders, but they also increase the degree of difficulty somewhat, so their placement in the arena should be carefully planned, well supervised and indicated in the posted pattern.

ARTICLE F2406 CLASS ROUTINE OVER FENCES

1. Classes should be held over reasonable hunter fences.
2. Each competitor will enter the ring and may circle once, if desired, before approaching the first fence. The rider shall then proceed around a course of not less than seven jumps, keeping an even pace throughout.
3. The fall of horse and rider and/or two disobediences shall cause the entry to be eliminated from the class.
4. "Hors concours" rounds are not permissible in equitation or medal classes. See Article G1001.4.

ARTICLE F2407 SCORING

Exhibitors are to be scored from 0 to infinity, with 70 denoting an average performance. Patterns will be divided into 6 to 10 maneuvers, as specified by the judge, and each maneuver will be scored from +3 to -3 with 1/2 point increments acceptable that will be added or subtracted from 70. Maneuver scores should be determined independent of penalties, and should reflect equal consideration of both performance of the exhibitor's pattern and the equitation form and effectiveness of the exhibitor to result in the following scores:

- +3 Excellent
- +2 Very Good
- +1 Good
- 0 Average or Correct
- 1 Poor
- 2 Very Poor
- 3 Extremely Poor

Exhibitors overall equitation form and effectiveness should also be scored from 0 to 5 with 0 to 2 Average, 3 Good, 4 Very Good, 5 Excellent. Exhibitors should also be judged on the rail, and their pattern score and/or ranking may be adjusted as appropriate. An exhibitor should be penalized in the pattern independent of maneuver scores and deducted from the final score as follows:

THREE POINT

- Break of gait at the walk or trot up to 2 strides
- Tick or hit of cone
-
- Missing a diagonal up to 2 strides in the pattern or on the rail

FIVE POINT

- Not performing the specific gait or not stopping within 10 feet (3 meters) of designated location
- Incorrect lead or break of gait at the canter (except when correcting an incorrect lead)
- Complete loss of contact between rider's hand and the horse's mouth
- Break of gait at walk or trot for more than 2 strides
- Loss of iron
- Head carried too low and/or clearly behind the vertical while the horse is in motion, showing the appearance of intimidation
- Obviously looking down to check leads or diagonals
- Missing a diagonal for more than 2 strides in the pattern or on the rail

TEN POINT

- Loss of rein
- Use of either hand to instill fear or praise while on pattern or during rail work
- Holding saddle with either hand
- Spurring or use of the of crop in front of girth
- Blatant disobedience including kicking, pawing, bucking, and rearing

DISQUALIFICATIONS (cannot place)

- Failure by exhibitor to wear correct number in visible manner
- Willful abuse of horse or schooling
- Fall by horse or exhibitor
- Illegal use of hands on reins Use of prohibited equipment
- Off pattern, including: knocking over or wrong side of cone or marker; never performing designated gait, lead, or diagonal; over or under turning more than 1/4 turn

ARTICLE F2408 NOVICE/ENTRY LEVEL CLASSES

Exhibitor going off pattern, knocking over or on wrong side of cone, never performing specified gait, lead or diagonal, shall not be disqualified, but must always place below exhibitors not incurring a disqualifying fault.

CHAPTER 25

WESTERN HORSEMANSHIP

ARTICLE F2501 WESTERN HORSEMANSHIP GENERAL

1. Riders will be judged on seat, hands, and ability to control and show horse. Results as shown by performance of the horse are NOT to be considered more important than the method used by the rider. The competitor's overall poise, confidence, appearance and position throughout the class as well as the physical condition of the horse will be evaluated
2. a) Rider should sit in center of saddle with legs under rider forming a straight vertical line through ear, center of shoulder, center of hip and back of heel. Stirrup length should allow heels to be lower than toes, with slight bend in knee, and toe directly under knee. Body should always appear comfortable, relaxed and flexible, and back should be nearly flat. Stiff and/or arched lower back should be avoided. Feet may be placed home in the stirrup, with boot heel touching the stirrup, or may be placed with ball of foot in the stirrup. Riding with toes only in stirrup and riding without contact of bottom of boot securely on pad of stirrup, will be penalized.
- b) Hands: Both hands and arms shall be held in a relaxed easy manner, with the shoulders back and down, and upper arm in a straight line with the body, the arm holding the reins bent at elbow forming a straight line from the elbow to the horse's mouth. When using a romal, the rider's off hand shall be around the romal with at least 16 inches of rein between the hands. Wrists are to be kept straight and relaxed, with thumb on top and fingers closed around the reins. One finger between the reins is permitted when using split reins, but not with a romal. Some movement of the arm is permissible, but excessive pumping will be penalized. Reins are to be carried immediately above or slightly in front of saddle horn. Only one hand is to be used for reining, and hand shall not be changed. Reins should be carried so as to have light contact with the horse's mouth and at no time shall reins be carried more than a slight hand movement from the horse's mouth. Excessively loose reins will be penalized. In the event a horse (five years of age or younger) is shown with snaffle bit or hackamore, it is legal for a rider to show with two hands on the reins, in accordance with the rules discussed earlier in this division.
- c) Position in Motion: Rider should sit to trot and not post. At the lope, the rider should remain seated. Rider should maintain vertical position at all gaits. All movements of horse should be governed by the use of imperceptible aids. Exaggerated shifting of the rider's weight is not desirable.. Judges shall not ask riders to mount or dismount.

ARTICLE F2502 WESTERN HORSEMANSHIP CLASS ROUTINE/CONDUCT

The judge will ask each rider to work individually. These individual works will be any of the maneuvers the judge feels are necessary to determine the horsemanship ability of the rider.

1. Individual work may be comprised of any of the following:
 - Walk, jog, lope, or gallop in a straight line, curve, or circle, or any combination of these gaits and patterns, such as a figure eight, etc.
 - Stop
 - Back

- Turn on the haunches, including spins and rollbacks, or on the forehand
 - Side pass
 - Simple change of lead through the jog, walk or halt, in a straight line, figure 8 or any other pattern Flying change of lead in a straight line, figure 8, or any other pattern
 - Markers help to standardize patterns and guide riders, but they also increase the degree of difficulty somewhat, so their placement in the arena should be carefully planned, well supervised and indicated in the posted pattern.
2. The judge must post the pattern that will be asked at least one hour prior to the class commencing.
 3. Failure to complete the pattern will not constitute elimination, but shall be scored accordingly.
 4. The whole class, or just the finalists, must work at all three gaits at least one direction of the arena. Judges should not ask exhibitors to mount or dismount.
 5. A back should be asked for at some time during the class.

ARTICLE F2503 SCORING

Exhibitors are to be scored from 0 to infinity, with 70 denoting an average performance. Patterns will be divided into 6 to 10 maneuvers, as specified by the judge, and each maneuver will be scored from +3 to -3 with 1/2 point increments acceptable that will be added or subtracted from 70. Maneuver scores should be determined independent of penalties, and should reflect equal consideration of both performance of the exhibitor's pattern and the horsemanship form and effectiveness of the exhibitor to result in the following scores:

- +3 Excellent
- +2 Very Good
- +1 Good
- 0 Average or Correct
- 1 Poor
- 2 Very Poor
- 3 Extremely Poor

Exhibitors overall horsemanship form and effectiveness should also be scored from 0 to 5 with 0 to 2 Average, 3 Good, 4 Very Good, 5 Excellent. Exhibitors should also be judged on the rail, and their pattern score and/or ranking may be adjusted as appropriate.

PENALTIES

An exhibitor should be penalized in the pattern independent of maneuver scores and deducted from the final score as follows:

THREE POINTS

- Break of gait at the walk or jog up to 2 strides
- Over or under turn from 1/8 to 1/4 turn
- Tick or hit of cone
- Obviously looking down to check leads

FIVE POINTS

- Not performing the specific gait or not stopping within 10 feet (3 meters) of designated location
- Incorrect lead or break of gait at the lope (except when correcting an incorrect lead)
- Break of gait at walk or jog for more than 2 strides
- Loss of stirrup
- Bottom of boot not touching pad of stirrup at all gaits including backup
- Head carried too low and/or clearly behind the vertical while the horse is in motion, showing the appearance of intimidation

TEN POINTS

- Loss of rein
- Use of either hand to instill fear or praise while on pattern or during rail work
- Holding saddle with either hand
- Cueing with the end of the romal
- Blatant disobedience including kicking, pawing, bucking, and rearing
- Spurring in front of the cinch

DISQUALIFICATIONS (cannot place)

- Failure to display correct number
- Abuse of horse or schooling
- Fall by horse or exhibitor
- Illegal equipment or illegal use of hands on reins
- Use of prohibited equipment
- Off pattern, including: knocking over or wrong side of cone or marker; never performing designated gait or lead; over or under turning more than 1/4 turn

ARTICLE F2304 NOVICE/ENTRY LEVEL CLASSES

Exhibitors going off pattern, knocking over or on wrong side of cone, never performing specified gait, or lead or overturning more than 1/4 turn than designated, shall not be disqualified, but must always place below exhibitors not incurring a disqualifying fault.

PART NINE

GENERAL PERFORMANCE HALTER CLASSES

CHAPTER 26

BREEDING/HALTER CLASSES

ARTICLE F2601 AGE REQUIREMENTS/ELIGIBILITY

For the purpose of determining eligibility for competition, the age of the horse shall be calculated by the calendar year, starting on January 1st, of the year foaled. Example: a horse foaled anytime during 1999, will be a yearling January 1st, 2000, and a two-year old on January 1st, 2001, and three-year old on January 1st, 2002, etc.

ARTICLE F2602 PRESENTATION

Horses are to be shown in hand with a serviceable halter or bridle, silver equipment will not count over a practical halter or bridle, at walk and trot. Horses should stand square on all four feet and are to be handled and shown throughout the entire class by only one person. Emphasis placed and credit given to the most positive combination of balance, structural correctness, and movement with appropriate breed and sex characteristics. Transmissible weaknesses to be counted strongly against breeding stock and horses must be serviceably sound.

Judges must disqualify and excuse from the ring prior to final placing a horse that:

- exhibits disruptive behavior such that it or other horses are unable to be inspected by the judge;
- exhibits disruptive behavior such that the safety of it, the handler, an exhibitor, a judge or another horse is endangered;
- is not under the control of the exhibitor;
- becomes detached from the exhibitor;
- has fallen and has its shoulder and hip touching the ground;
- is observed with raw or bleeding sores, or evidence of other blood on the horse's body, including, but not limited to, the nose, chin, mouth, tongue, or gums, regardless of cause.

ARTICLE F2603 CONFORMATION

Must be relative to Breed.

1. a) A halter class is defined as a class where the horse is judged based upon its conformation. Characteristics should be coupled with straight and structurally correct legs and feet that are free of blemishes. The horse should be a balanced athlete that is muscled uniformly throughout.
b) Conformation is defined as the physical appearance due to the arrangements of muscle, bone and other body tissues.
2. Procedure for Judging the Class:
 - a) Horses will walk to the judge one at a time. As the horse approaches, the judge will step to the right (left of the horse) to enable the horse to trot straight to a cone placed at 50 feet away. At the cone, the horse will continue trotting, turn to the left and trot toward the left wall or fence of the arena. After trotting, horses will be lined up head to tails for individual inspection by the judge. The judge shall inspect each horse from both sides,

front and rear.

- b) All stallions three-years-old and over shall have two visible testicles. All mares and stallions shall be examined for parrot mouth. All lame horses, crypt orchids and parrot mouthed horses should be excused from the ring prior to final placing by the judge. The judge should line the horses to be placed in a head to tail order according to preference.

ARTICLE F2604 CLASS DIVISIONS

1. The following classes are recommended (horses of different sexes should not be combined in one class):
 - a) Yearlings, colts, fillies or geldings
 - b) Two-year old, colts, fillies geldings
 - c) Three-year old stallions, mares and geldings
 - d) Four-year old and older stallions, mares and geldings.
2. Grand Champions and Reserve Champions shall be awarded to one of the horses which has placed first in a qualifying class. After the Championship has been awarded the horse which has placed second in the qualifying class to the horse awarded the championship shall compete with the remaining first place winners for the Reserve Championship.
3. If the first place horse does not return for any reason, the second place horse will move up to first place line and be considered for Grand and Reserve. The third place horse cannot move up to second place in the class. All first place horses will retain points in their respective class.

APPENDIX 1
HUNTER AND JUMPER: DIAGRAMS AND CHARTS:
DISTANCES

NUMBER OF STRIDES	NORMAL	SHORT	LONG
2 Strides Jumper only Not recommended	36 FT	35 FT	
4 STRIDES	60 FT 18.30 M	58 FT 17.40 M	61 FT 19.80 M
5 STRIDES	72 FT. 22 M	70 FT 20.70 M	73 FT 23.80 M
6 STRIDES	84 FT 25.60 M	82 FT 24.40 M	85 FT 27.50 M
7 STRIDES	96 FT 29.30 M	94 FT 27.80 M	97 FT 31.30 M

The long distances should ONLY be considered if the ring is a large outdoor ring and the horses are well broke.

GLOSSARY

AD

Advanced

ADULT

Individuals are adults from the beginning of the calendar year in which they reach the age of nineteen. For exceptions, see discipline/breed sport rules.

AFFILIATE ORGANIZATIONS

Canadian equine or equestrian organizations with aims and objectives of national scope may apply to become affiliate members of EC. See Article A211, Affiliate Membership.

AGE OF A HORSE

A horse is considered to be one year old on January 1 following the actual foaling date.

AGE OF A PARTICIPANT

Except as modified by discipline/breed sport rules, a participant is considered to be a certain age until the end of the calendar year in which he or she turns that age. For example, riders remain Junior A until the end of the calendar year in which they turn 18.

AGENT

Any adult or group of adults acting on behalf of an owner or lessee.

AM

Amateur

AMATEUR

For the purposes of these rules, an amateur is an adult Sport Licence holder who is eligible to compete in EC amateur classes as per EC regulations. See Article A902, Amateur Competitors, and specific discipline/breed sport rules.

APPEALS

An appeal may be made against the decision of a competition organizing committee or against the decision of a hearing panel, provincial, territorial or national, regarding a protest or complaint. See Articles A1211 and A1212.

“B”

Basic (Judge or Steward)

BOARD/BOARD OF DIRECTORS

The Board of Directors of Equestrian Canada.

BORROWED HORSE

A horse not owned by the rider competing in a Para-Equestrian Canada class.

CALENDAR YEAR

The calendar year starts on January 1 and ends on December 31.

CANADIAN ANTI-DOPING PROGRAM (CADP)

Canada's national anti-doping organization, Sport Integrity Canada, implements and administers the CADP on behalf of the Canadian sport community. It's designed to prevent, deter and detect doping and serves to protect the integrity of sport and the rights of clean athletes. The CADP is compliant with the World Anti-Doping Code and all International Standards that address technical areas and the associated Technical Documents.

CANADIAN OLYMPIC COMMITTEE (COC)

The Canadian Olympic Committee, the governing body for all Olympic disciplines in Canada. EC is a member of the COC.

CANADIAN PARALYMPIC COMMITTEE (CPC)

The Canadian Paralympic Committee (CPC) National Paralympic Committee for Canada and is a member of the International Paralympic Committee (IPC). Equestrian Canada is a member of the CPC.

CAP

See "Competition Administration Policy".

CARDED ATHLETES

Carded Athletes refers to athletes who are approved for funding and are directly financially support by Sport Canada through the Athlete Assistance Program (AAP). AAP support is referred to as CARDING.

CATEGORY

Refers to the eligibility of the athlete defined by age, amateur status, open, etc.

CDI

Concours Dressage Internationale

CDN

Canadian

CERTIFIED COACH

Equestrian Coaches who have completed an evaluation and are certified by EC in partnership with the Coaching Association of Canada. The following designations are available: Instructor, Competition Coach, Competition Coach Specialist, High Performance 1.

CERTIFIED INSTRUCTOR

Equestrian Instructors who have completed an evaluation and are certified by EC in partnership with the Coaching Association of Canada.

CET

Canadian Equestrian Team

CHILDREN

Juniors competing in classes designated as children's classes. See discipline/breed sport rules for cross-entry restrictions.

CLASSES

1. Amateur/Amateur-Owner Class. For adult riders/drivers who hold a valid Sport Licence and EC amateur card or, when competing in their own breed divisions or classes, a valid amateur card from their breed or discipline affiliate organization. Riders/drivers from other countries must have a valid amateur card from their national federation. In amateur-owner classes, riders/drivers or members of their immediate family must own the horse. See also 13. Owner Classes
2. Canadian-Bred Class. A Canadian-bred class is limited to entries of horses bred and foaled in Canada.
3. EC Point Classes. Classes in which competitors accumulate points at EC competitions towards annual EC awards.
4. Family Class. A class for two or more members of a family.
5. Gentlemen's Class. A class for gentlemen which may be restricted to riders, drivers or handlers who are no longer eligible to compete as juniors, unless otherwise specified in discipline/breed sport rules.
6. Ladies' Class. Class for ladies which may be restricted to riders, drivers or handlers who are no longer eligible to compete as juniors, unless otherwise specified in discipline/breed sport rules.
7. Limit Class. Limit classes are for horses or competitors that have not won six first place ribbons at EC Gold competitions or at USEF competitions in the particular performance classes in which they are being shown excepting winnings in four-in-hands, tandems, teams, unicorns, and pairs, and winnings in combined driving, local, model and breeding classes, unless otherwise specified in discipline/breed sport rules. A limit entry is such from the closing date of entries.
8. Local Class. A class held at an EC-sanctioned competition, which is restricted by geographic area but which is run according to all other EC rules. Local classes are not eligible for national or regional championships nor shall they count towards EC awards. See EC Competition Administration Policy, Local and Miscellaneous/Additional Classes.
9. Maiden Class. A class open to horses or competitors that have not received one first place ribbon at EC Platinum, Gold or Silver competitions or USEF competitions in the particular performance classes in which they are shown. A maiden entry is such until the closing date of entries.
10. Miscellaneous Class. A class which meets the particular requirements of a competition and is beneficial to the area but does not conform to the specifications for any class or division included in these rules. Entries in these classes will not accumulate points towards EC awards. Such classes or divisions must be identified in the prize list as "not rated for EC awards".
11. Novice Class. A novice class is open to horses or competitors that have not won three first place ribbons at EC Platinum, Gold or Silver competitions or USEF competitions in the particular performance classes in which they are shown, unless otherwise specified in discipline/breed sport rules. A novice entry is such until the closing date of entries.
12. Open Class. A class that is open to all horses of any age or breed, irrespective of ribbons previously won, and in which there is no qualification for the rider or driver.
13. Owner Classes. Open to adult riders/drivers who are owners or members of the owner's immediate family. Leased horses are not eligible and multiple ownership is not permitted unless all owners are members of the

same immediate family and members of EC. See discipline/breed sport rules for specific restrictions.

14. Parent and Child Class. For a parent and child. The age of the child may be specified. To be judged as a Family or Pair class using specifications in the discipline/breed sport rules.
15. Restricted Class. A class in which entries are restricted or limited in any way (i.e. according to money or ribbons won, years of competition, age, etc.)

Note: Classes restricted by geographic area are Local Classes.

CLASSIFIER A Para Equestrian Classifier is an individual trained and qualified to administer athlete classification nationally and/or internationally.

CLASSIFICATION

Classification is undertaken to ensure that an Athlete's impairment is relevant to performance on the horse. Classification aims to place athletes into classes or Grades according to how much their impairment impacts on the core determinants of success in the sport. Classification ensures the Competition within each Grade can then be judged on the functional skill of the rider regardless of impairment.

CLIENT

Any person who pays a fee for equestrian and/or equine-related services.

COACH

An adult who instructs and educates riders or drivers. See also CERTIFIED COACH

COC

See "Canadian Olympic Committee".

COMPETITION

1. For the purposes of these rules, the term competition includes all shows, events, horse trials and any other form of equestrian competition that is covered by these rules.
2. Platinum Competition. A term for a competition that is operating a Gold EC-sanctioned competition and an FEI sanctioned competition at the same time and venue.
3. Gold Competition. This category of competition formerly called a National Competition is subject to the rules set out in the Rules of Equestrian Canada. Points accumulated at EC Gold sanctioned competitions apply towards the EC awards programs.
4. Silver Competition. A category of competition sanctioned by Equestrian Canada, organized and named by the province subject to the rules set out in the Rule Book. Competitors in this category of competition are not eligible to accumulate points for annual EC championship awards. Provinces may establish their own awards program for these competitions.
5. Bronze Competition. A grass-roots category competition (similar to the former Primary Competition) sanctioned by EC and subject to the rules set out in the Rules of Equestrian Canada, subject to discipline-specific restrictions. Competitors in this category of competition are not eligible to accumulate points for annual EC championship awards. Provinces may establish their own awards program for these competitions.

6. Sanctioned Competitions. Bronze, Silver, Gold and Platinum competitions are all sanctioned by Equestrian Canada and are subject to the rules set out in the Rules of Equestrian Canada.

COMPETITION ADMINISTRATION POLICY (CAP)

This policy outlines the three-stage process for obtaining an EC-sanctioned competition sanction/licence, and the responsibilities of the competition organizing committee, the Participating Provincial or Territorial Sport Organization (PTSO) and Equestrian Canada regarding sanctioned competitions.

COMPETITION EMPLOYEES AND OFFICIALS

All persons directly employed by the competition, and all individuals officiating at a competition including but not limited to judges, stewards, course designers, technical delegates, veterinarians, timekeepers, announcers and ringmasters. See also Licensed Officials.

COMPETITION MANAGER

A person designated to manage a competition (see Competition Administration Policy 5.1.2). This person must hold a valid EC Sport Licence at or above the level of the competition, and must be in good standing.

COMPETITION ORGANIZING COMMITTEE OR MANAGEMENT All persons who are responsible for all or part of the management and organization of a sanctioned competition including but not limited to members of a competition's Board of Directors, the officers, competition committee chairperson or president, manager and secretary.

COMPULSORY TURNING FLAG (CTF)

In driving, a pair of markers used to define the required track of the Marathon course. Each CTF must be numbered consecutively within the section and placed so they are clearly visible to be passed with the red marker on the right and white on the left. Numbering shall be affixed to the right hand marker using the shapes and colours defined for each division (Article C960.5)

COMPETITION YEAR

The competition year is the calendar year.

COMPETITOR

The person entered in a competition as a rider, driver, vaulter or handler.

1. Rider – directs the movement of or controls the horse from a saddle.
2. Driver – directs the movement of or controls the horse from either the ground or on a vehicle using a lead, lunge or reins augmented by whip and voice as the primary aids.
3. Vaulter – performs gymnastic and dance exercises on the back of a moving horse. A vaulter is not a rider, as the horse's movement is directed and controlled by a lunger using a lunge line, a lunge whip, and static side reins.
4. Handler – directs and controls the movement of the horse other than as specified above.

COMPLAINT

A formal submission in writing on the required form stipulated within the EC Discipline, Complaints and Appeal Policy setting out the details of an alleged complaint, violation, breach, or grievance.

CONFLICT OF INTEREST

A substantial appearance of a conflict of interest exists whenever others may reasonably infer from the given circumstances that a conflict exists. A conflict of interest is defined as any personal, professional or financial relationship, including, but not limited to, relationships of family members that could influence or be perceived to influence objectivity when representing or conducting business or other dealings for, or on behalf of EC. For example, a person is considered to be in conflict of interest if that person or that person's family stands to benefit from a decision or from information obtained in the course of official duties and responsibilities which is not generally available to the membership or the public. See Chapter A14, Conflict of Interest Provisions.

CPC

Canadian Pony Club

DISMOUNTING

The deliberate departure of a person from the horse/carriage or the accidental leaving (falling off) of the horse/carriage .

DISQUALIFICATION

Disciplinary action, prohibiting a competitor and/or entry from any further participation for the duration of a competition, and usually requiring the forfeiture of all winnings and the loss of entry fees.

DIVISION

A grouping of entry based on competition criteria. Example: Training, Preliminary, Intermediate, Intermediate II, Advanced.

Blocks of FEI tests written by FEI and used by EC. Always prefaced by the abbreviation "FEI ...".

DRP

Dispute Resolution Path/Process

DRR

Dispute Resolution Request

EC DRESSAGE COMMITTEE

The National Committee responsible for the development of Dressage in Canada.

EC DRIVING COMMITTEE

The National Committee responsible for the development of driving in Canada.

EC EVENTING COMMITTEE

The National Committee responsible for the development of Eventing in Canada.

EC JUMPING COMMITTEE

The National Committee responsible for the development of the hunter, jumper and equitation divisions of equestrian sport in Canada.

EC NATIONAL PASSPORT

The EC national passport is for use in FEI CIM-level competitions within Canada by Canadian owned horses. Please note that Canadian owned horses competing outside of Canada will require an FEI Passport or FEI Recognition Card. Horses competing with the EC National Passport in FEI competitions must also have an annual FEI Registration. Horses competing in CI-level competitions or FEI competitions outside of Canada, must upgrade to an FEI Recognition Card.

EC PARA-DRESSAGE COMMITTEE

The National Committee responsible for the development of Para-Dressage in Canada.

EC

Equestrian Canada

EC/USEF RECIPROCAL AGREEMENT

An agreement between EC and USEF on the recognition and suspension of officials, amateur certification and jointly recognized competitions.

ELIMINATION

Exclusion from any further participation in the class in which the elimination occurs.

ENTRY

Horse or pony entered in competition, or, in equitation, horsemanship or reinsmanship classes, the rider or driver respectively.

ENTRIES

1. Applications to compete in an EC-sanctioned competition, which must be signed by an individual who holds a valid EC Sport Licence or member of the national federation of another country, excepting parents or guardians signing an entry for a junior. See Chapter A9, Entries.
2. Late entry. An entry made and accepted after the closing date of entries and before the commencement date of the competition.
3. Post-entry. An entry made after the commencement of the competition or after the closing of entries, depending upon the rules of each competition.
4. Regular entry. An entry made before the closing date for regular entries.

EQUESTRIAN CANADA (EC)

Equestrian Canada is the national governing body for all equine and equestrian sporting and recreational activities and interest (except racing) in Canada. If the name of EC changes at any time, any reference to EC will refer to its replacement name or organization.

EVENT

The entirety of activities, classes, competitions or combinations thereof, commencing and concluding as defined by the Organizer in the Prize List and which is covered by these rules. Also see "Competition".

EVENT LOCATION

All lands used by the competitions comprising the event. The competition rings, arenas, warm-up areas, stabling, parking and all grounds available or used for an event or competition owned, leased or rented by the Organizing Committee for the purposes of holding an EC-sanctioned event.

EVENTING

EC rules for the discipline of Eventing, formerly called Combined Training, cover Horse Trials, Two-Day Events and Three-Day Events.

FALLS

Competitors are considered to have fallen when, either voluntarily or involuntarily, they are separated from their horse, which has not fallen, in such a way that they touch the ground or find it necessary, in order to get back into the saddle, to use some form of support or outside assistance.

1. A horse is considered to have fallen when at the same time both its shoulder and quarters have touched either the ground or the obstacle and the ground.
2. See also discipline/breed sport rules.

FEDERATION

For the purposes of these rules, the “Federation” means Equestrian Canada or the replacement organization should its name change.

FÉDÉRATION EQUESTRE INTERNATIONALE (FEI)

The Fédération Equestre Internationale is the international equestrian sport governing body, of which EC is a member.

FEES, NOMINATION AND START

1. **Nomination Fee.** A fee, usually non-refundable, which is levied by the competitions and, in some cases, organizations sponsoring special competitions such as futurities, to establish eligibility and intent to enter classes or divisions or special events. The fee constitutes a part of the total entry fee and allows the competitor the option to compete, usually upon payment of an additional fee, in the classes or divisions or special events for which the nomination fee was paid.
2. **Start Fee.** An additional fee levied by the competition applied to previously nominated entries and paid before commencement of a class. Payment of the fee allows the entries to compete in the class for which they have been nominated.

FEI

See Fédération Equestre Internationale

FEI SCHEDULE

An official document approved by the FEI outlining relevant information of an Event, including but not limited to the dates and location of the Event, the dates by which entries must be received, the Disciplines in which Competitions will be held, the programme of Competitions, the categories, nationalities and other relevant details of invited Athletes and Horses, the stabling and accommodation available, the value of the prizes and their distribution, and any other relevant details.

FEI 1*2*3* 4* 5*

Categories of FEI sanctioned competition and certification classification of FEI Officials.

GATE

In driving: A pair of lettered or unlettered markers used in an obstacle to define the route.

GENERAL PERFORMANCE DIVISION

A multi-performance division open to all horses, with classes conducted according to the General Performance rules. See Section F, General Performance.

GOOD STANDING

Participants in good standing are individuals who hold sport licences with Equestrian Canada who have paid their current licence dues, are not currently suspended and/or are not subject to any form of disciplinary action as described in these rules.

GP

Grand Prix

GPS

In dressage; Grand Prix Special

GPF

In dressage; Grand Prix Freestyle

GROOM, ATTENDANT OR ASSISTANT

A person who assists a competitor.

GUEST CARD

A guest card is a temporary licence issued by EC for officials not listed in the current EC Officials Roster or not listed in the capacity or with the qualifications which the competition requires.

HAND

A hand is a unit of measurement that may be used to determine the height of a horse or pony. A hand measures four inches. Equines may also be measured in centimetres.

HANDLER

See "Competitor".

HEADER

In driving; A groom or passenger, who "heads" a horse in a lineup in a driving class.

HEADGEAR STANDARDS

Protective headgear designed for equestrian sport must be certified under one of the following standards: ASTM (American Society for Testing Materials)/SEI (Safety Equipment Institute, Inc.); BSI/BS EN (British Standards Institution); EN

(European Union Standards); AS/NZS (Australian/New Zealand Standards); or CE VG1 01.040 2014-12 (provided they are BSI Kitemarked).

HORS CONCOURS

Non-competitive entry, entered in a competition with the permission of the organizing committee. Not eligible for any winnings at that competition from the time it performs hors concours. See discipline/breed sport rules.

HORSE

The term “horse” in this Rule Book, unless otherwise stated, denotes a horse, pony, mule, donkey, zebra or Very Small Equine (VSE). For competition purposes, a horse is over 14.2 hands high. For exceptions, see discipline/breed sport rules.

HORSE RECORDING

A Horse Recording is a digital identification document for horses competing at EC Silver, Gold and Platinum competitions. The purpose of a Horse Recording is to enable EC to create a database profile for every horse competing at EC-sanctioned competitions. This allows EC to:

- Track the number of competitions, and classes per competition, that a horse is entered in to protect horse welfare.
- Record competition results to aid owners in the marketing and sale of horses, and to identify successful bloodlines.
- Assist in horse identification and safeguard against horse misrepresentation.
- Track eligibility of all horses and ponies, and record official pony measurements, to ensure fair play.
- Accurately track horses throughout their lifetime, regardless of ownership and/or horse name changes.

I1

In dressage; abbreviation for the Intermediate 1 test

I2

In dressage; abbreviation for the Intermediate 2 test

IMMEDIATE FAMILY / FAMILY

The words “immediate family” and “family” include the following: husband, wife, spouse, common law, same- or opposite-gender partner, parent, child, step-child, brother, sister, half-brother and sister, step-brother and sister, in-laws of the same relation stated above, grand-parents and grand-children, unless otherwise stipulated in discipline/breed sport rules.

JR

Junior

JUDING PANEL

Two or more judges on the ring at the same time

JUNIOR/YOUTH

1. Except as modified by discipline/breed sport rules, individuals are juniors until the end of the calendar year in which they reach the age of 18.

2. Junior "A". Riders/drivers are classified as Junior "A" from the beginning of the calendar year in which they turn 16 until the end of the calendar year in which they turn 18.
3. Junior "B". Riders/drivers are classified as Junior "B" from the beginning of the calendar year in which they turn 13 until the end of the calendar year in which they turn 15.
4. Junior "C". Riders/drivers are classified as Junior "C" such until the end of the calendar year in which they turn 12.

In Western classes, individuals are youths until the end of the calendar year in which they turn 19. See also discipline/breed sport rules.

JURY

For the purposes of these rules, a jury is deemed to be one judge or any number of judges as required by the class or event rules.

LAMENESS CATEGORIES

Grade I: is defined as lameness difficult to observe. Not consistently apparent regardless of whether the horse is circling, going up or down a hill, trotting on a hard surface, etc.

Grade II: is defined as lameness difficult to observe at a walk or trot on a straight line.

Grade III: is defined as a consistently observable lameness at a trot.

Grade IV: is defined as an obvious lameness with marked nodding.

Grade V: is defined as minimal weight bearing on one leg, or inability to move.

In endurance; Grades III to V are automatically excused from BC judging; Grades I and II usually are not. The "soundness" score should reflect the significance of the gait impairment as well as the degree of impairment at that moment. A horse that merely has a peculiar way of going may appear slightly "off" so it is very important for the vet to have made notes, whether mental or otherwise, about how each horse moved at the pre-ride exam.

LESSEE

An individual or group of individuals leasing a horse; to be official the lease must be registered with EC..

LEVEL

Blocks of EC national dressage tests written by the USEF and used by EC. Refers to Training through Fourth Level and all Freestyles.

"M"

Medium (Judge or Steward)

MEMBER

Members of Equestrian Canada, including Category A, Category B and Category C members; see Equestrian Canada Bylaws, Article 3 – Membership. The term

“member” may also be used in these rules to refer to a member of an organization such as FEI / USEF. See also Registered Participant

NATIONAL CHAMPIONSHIPS

Any national competition may apply for National Championships through the EC National Office and pay the required fees.

NATIONAL FEDERATION (NF)

The national sport governing body of a country, which is a member of the FEI.

NATIONAL OFFICE (EC)

The administrative office of EC.

NATIONAL ORGANIZATION

A Canadian equine or equestrian society or organization, which has objectives and aims with Canadian scope, is registered in Canada, has a Canadian head office and a Canadian Board of Directors.

NF

See National Federation

O

Open

OFFICIALS

Officials, including judges, stewards, course designers and technical delegates, who are recognized and certified by Equestrian Canada to officiate at EC-sanctioned competitions.

PARTICIPANT

Any person involved with, competing in, taking part in, in any capacity with regards to the said event. Said “event” is not restricted to competition and could include but is not limited to clinics, shows, competitions, demonstrations and training sessions. See also Registered Participant.

PARTICIPATING PTSO

A Provincial or Territorial Sport Organization that has a current Affiliation Agreement with Equestrian Canada to provide various services and products and represents the aims and objectives of the national federation in its region.

PERSON(S) RESPONSIBLE

The Person(s) responsible (PR) for a horse must be an adult who has, or shares responsibility for the care, training, custody, and performance of the horse and who has official responsibility for that horse under EC Rules. The PR is liable under the penalty provisions of the applicable EC Rules for any rule violations.

Every entry form for an EC sanctioned competition must identify the PR and be signed by the PR.

The Person(s) responsible is ultimately responsible for the condition, fitness and management of the horse and is alone responsible for any act performed by himself/herself or by any other person with authorized access to the horse in the

stables, elsewhere on the grounds, or while the horse is being ridden, driven or exercised.

A: For adult entries into EC sanctioned competitions the PR shall be either the trainer, the owner of the horse or the competitor who rides or drives the horse during the EC sanctioned competition.

B: For Junior entries into EC sanctioned competitions the Junior competitor cannot be the PR. For Junior entries the PR may be either the trainer, the owner of the horse, or a parent/guardian of the Junior competitor.

PONY

1. Ponies are animals that do not exceed 14.2 hands, unless otherwise specified in discipline/breed sport rules.
2. "A" ponies exceed 13.2 hands but do not exceed 14.2 hands
3. "B" ponies exceed 12.2 hands but do not exceed 13.2 hands
4. "C" ponies do not exceed 12.2 hands

PRIZE LIST

Required for all EC-sanctioned competitions. A publication which serves as an invitation to compete and provides all information required by the officials and the competitors in the competition. See Chapter A6, Prize Lists and Entry Forms.

PRIZE MONEY

Includes bonus money, cash, or gift cards/certificates, and exhibition class prize money.

PROTECTIVE HEADGEAR

1. Protective headgear must be:
 - a) approved by an accredited certification organization (HEADGEAR STANDARDS).
 - b) designed specifically for equestrian sport;
 - c) properly fitted; and
 - d) securely fastened by a permanently affixed safety harness.
2. Any competitor may wear approved protective headgear in any division or class without penalty from the judge.
3. Equestrian Canada makes no representation or warranty, expressed or implied, about any approved protective headgear. Equestrian Canada cautions riders and Athletes that serious injury or death may result despite wearing such headgear, as all equestrian sports involve inherent risk, and no protective headgear can protect against all foreseeable injury.

PROTECTIVE VEST (BACK PROTECTORS)

1. Protective vest must be:
 - a) properly fitted; and
 - b) securely fastened.
2. Any competitor may wear a protective vest in any division or class without penalty from the judge.
3. Equestrian Canada makes no representation or warranty, expressed or implied, about any protective vest and does not imply protective vests may protect against all foreseeable injury.

PROTEST

A formal process, expressed in writing, to the Competition Organizing Committee (OC) to lodge a dispute, disagreement or grievance regarding the conduct of the EC-sanctioned competition or an alleged rule or policy violation on the part of the OC or official(s) at an EC-sanctioned competition. See Article A1204 – Filing a Protest.

PROVINCE (PARTICIPATING PTSO)

For the purposes of these rules, the term “Province” refers to the Provincial or Territorial Equestrian Sport Organization,

PSG

In dressage; Prix St. Georges

PTSO

Provincial/Territorial Sports Organization (provincial or territorial organization overseeing equestrian activities)

“R”

Recorded (Judge)

RAPPING

The term “rapping” is construed to include all of the artificial techniques intended to induce a horse to jump higher or more carefully in competition. It is not practical to list every possible means of rapping, but in general it consists of the competitor — and/or dismounted assistants, for whose behavior the competitor is responsible — either hitting the horse’s legs manually with something (no matter with what or by whom) or deliberately causing the horse to hit something itself, whether by building fences too large and/or too wide, setting false ground lines, placing trot poles or elements of a combination at a false distance, intentionally pushing the horse into a fence or otherwise making it difficult or impossible for the horse to negotiate the practice obstacle without hitting it.

RECORDED WARNING

An alternative to other options in the EC legal system, (eg. Fines or disqualification) and is for cases of minor offenses, including behaviour that should not be repeated and that does not warrant a more severe penalty, including a Yellow Warning Card.

REGISTERED LEASE

A lease registered with EC or the FEI. See Article A817, Registered Leases.

REGISTERED PARTICIPANT

Any Person registered with Equestrian Canada, including Sport Licence Holders, and paying dues to obtain some benefit from Equestrian Canada. Registered Participant status is included with a PTSO membership.

REMUNERATION

For the purposes of these rules, remuneration is defined as any payment, either in cash or in kind, with the exception of gifts of token value.

1. Remuneration does NOT include:
 - a) payment made to any competition official

- b) reimbursement for expenses without profit
- c) winnings paid to a horse's owner

RULE BOOK/RULES

“Rule Book” refers to the Rules of Equestrian Canada and all its parts. “Rules” refer to the rules and regulations of EC contained in the Rule Book.

“S”

Senior (Judge or Steward)

SCHOOLING

The act of preparing or exercising a horse prior to or between competition rounds, which may include flatwork, jumping, or other permitted training activities. Schooling may take place in designated schooling areas, competition rings (when authorized), or other approved spaces under the supervision of competition officials.

All schooling must be conducted in accordance with Equestrian Canada rules, with attention to horse welfare, safety, and fair sport.

SCHOOLING AREA

A designated space provided at a competition venue for the purpose of allowing competitors to warm up and prepare their horses prior to entering the competition ring.

Schooling areas must be safe, clearly marked, and managed in accordance with the discipline-specific rules. They may include warm-up rings, lungeing areas, and any other spaces explicitly permitted by the Organizing Committee for horse preparation.

All schooling areas fall under the jurisdiction of the competition and must comply with Equestrian Canada safety standards and horse welfare policies.

SENIOR

Individuals are adults or seniors from the beginning of the calendar year in which they reach the age of nineteen. For FEI rules visit www.fei.org

SHOWN AND JUDGED

To be “shown and judged” in a class, an animal must perform the prescribed routine and must remain in the ring until excused by the judge.

SOCIAL MEDIA BRAND AMBASSADOR

A Social Media Brand Ambassador is a social media user who spreads the word about a company/brand or its products by posting about them on social media and promoting them to their unique social audience.

SOCIAL MEDIA INFLUENCER

A Social Media Influencer is an individual who has built a reputation for their knowledge and content creation on a specific topic. They make regular posts about that topic on their preferred social media channels and generate large followings of enthusiastic, engaged people who pay close attention to their content.

SOUNDNESS

Must be serviceably sound. See also Unsoundness.

SPORT INTEGRITY CANADA

Sport Integrity Canada (formerly The Canadian Centre for Ethics in Sport (CCES)) is an independent, national, not-for-profit organization that works to protect and promote the integrity of sport in Canada. Through the administration of its programs, including the Canadian Anti-Doping Program and the Canadian Safe Sport Program, we strive to ensure sport is safe, inclusive, fair, clean, and accessible for all Canadians.

SPORT LICENCE

EC Sport Licences are required by competitors, owners or lessees, and individuals/corporations accepting responsibility for entries in EC-sanctioned competitions.

START OF A COMPETITION

The official start of a competition relates to the same day that officials are required to be on duty. For exceptions, see discipline/breed sport rules.

SUITABILITY

Suitability (rider-to-horse combination):

The appropriateness of a competitor's size, weight, balance, and ability relative to the horse or pony, such that it does not compromise the animal's welfare, soundness, safety, or performance. Officials may consider factors such as the competitor's height and weight in proportion to the horse, competitor skill level, and the horse's build, fitness, and observable reaction under saddle.

SUSPENSION

Disciplinary action resulting in the suspension of a horse and/or owner, lessee, rider, driver, handler or any other responsible party from further participation in EC-sanctioned competition until the term of the suspension has expired.

TRAINER

An adult who has the responsibility for the care, training, custody and performance of the horse.

TROPHY

1. Challenge Trophy - A challenge trophy has to be won a specified number of times for outright possession.
2. Perpetual Trophy - A perpetual trophy remains in the possession of the winner for a period of 11 months, at the end of which time it is to be returned to the competition organizing committee. A replica may be given instead of a perpetual trophy.

TURNOUT

In driving; The assemblage including the Athlete (Athlete), required groom(s), horse(s) with harness and carriage appropriate to the competition. Description includes configuration – single, pair, tandem, unicorn or four-in-hand. Examples: Horse single; pony pair; VSE unicorn; Small pony tandem

UN SOUNDNESS

Unsoundness is:

- a) consistently observable at any gait under all circumstances;
- b) marked nodding, hitching or shortened stride; or

- c) minimal weight-bearing in motion and/or rest and inability to move.
- d) Any manifestation of pain, inability, disability or deformity in the act of motion is considered an unsoundness.

UNITED STATES EQUESTRIAN FEDERATION (USEF)

The equestrian sport governing body of the United States.

USDF

United States Dressage Federation

USEF

United States Equestrian Federation

VALID SPORT LICENCE

A Sport Licence is considered valid when it is current and the holder is in good standing.

VETERINARIAN

Veterinarian: the veterinarian must be licensed to practice in the province/territory in which the competition is being held or in the home province/territory of the horse that is in competition and owner of or employed by a practice that is approved by its province/territory to participate in equine practice.

VIOLATION

For the purpose of these rules, a violation is deemed to be any act prejudicial to the interests of EC. See Article A1207 – Violations.

WINNINGS

All ribbons, prizes, prize money, trophies and points won by a horse.

YELLOW WARNING CARD

An alternative to other options in the EC legal system, (eg. recorded warning, fines or disqualification) and is for misconduct that is not a minor offense but not severe enough to warrant formal disciplinary action by EC.

YR

Young Rider

YOUNG RIDER/DRIVER

Young riders/drivers are such from the beginning of the calendar year in which they reach the age of sixteen until the end of the calendar year in which they reach the age of 21.

METRIC CONVERSION

<u>WHEN YOU KNOW</u>	<u>MULTIPLY BY</u>	<u>TO FIND</u>
Hands	4	inches
Inches	2.54	Centimeters
Centimeters	0.3937	Inches
Yards	0.9	Meters
Meters	3.281	Feet
Feet	0.3048	Meters
Miles	1.609	Kilometers
Kilometers	0.6214	Miles
Pounds	0.4536	Kilograms
Kilograms	2.205	Pounds

INDEX

For definitions of terms, see the Glossary.

Amendment of the Rules	v	Interpretation of the Rules	vi
Awards		Judges	
Western competitions	4	General Performance	1
Western Performance	9	Western	2
Barrel racing classes	52	Jumper division classes	66
Barrel racing patterns	53	Jumper tack	67
Classes		Keyhole race pattern	59
Barrel racing	52	Metric conversion chart	106
Command	33	Organization of the Rulebook	v
English Pleasure - Open	74	Patterns	
English under saddle	71	Barrel racing	53
Hunt Seat	79	Flag race	57
Jumper	66	Keyhole race	59
Open English Pleasure	74	Pole-bending	55
Pole-bending	54	Reining	36
Reining	34	Stake race	58
Showmanship at halter	75	Trail Horse	21
Stake race	58	Western Riding	31
Western Horsemanship	83	Pole-bending	
Western Performance	6	Classes	54
Western Pleasure	14	Patterns	55
Western Riding	27	Provincial Awards	
Combined competitions	4	Western Competitions	4
Dash for cash class	60	Rapping	63, 67
Extraordinary Rule Amendment		Reining	
(ERA) process	vi	Classes	34
Fence heights	66	Patterns	36
Flag race classes	56	Penalties	35
Flag race patterns	57	Rule interpretation	vi
General Performance		Showmanship at halter classes	75
Equitation	78	Stake race	
Hack classes	72	Class	58
Hunt Seat Equitation	79	Pattern	58
Judges	1	Tack	
Showmanship at Halter	75	Hack Division	72
Stock Seat equitation	83	Hunt Seat	79
Guest Cards		Jumper	66
Western Judges	2	Western	10
Hack division		Trail Horse classes	16
Tack	72	Trail horse patterns	21
Hunt Seat equitation classes	79	Western	
Hunter and Jumper		Attire	10
Diagrams/distances	88	Western competitions	
Hunter and Jumper		Classification	4
Classes	61	Western Horsemanship classes	83
Hunter under saddle class	71	Western Judges	

Application2
Guest cards2
Western Performance
Classes6

Terminology 6
Western Riding
Patterns31



**EQUESTRIAN
CANADA
ÉQUESTRE**

EQUESTRIAN.CA